

# OKI Semiconductor

1A

## MR27V1652D

1,048,576-Word x 16-Bit or 2,097,152-Word x 8-Bit

8-Word x 16-Bit or 16-Word x 8-Bit Page Mode

Production Programmed Read Only Memory (P2ROM)

### DESCRIPTION

The MR27V1652D is a 16Mbit Production Programmed Read-Only Memory (P2ROM) with page mode. Its configuration can be electrically switched between 1,048,576 word x 16bit and 2,097,152 word x 8bit. The MR27V1652D operates on a single +3.3V power supply and is TTL compatible. The MR27V1652D provides Page mode which can greatly reduce the read access time. Since the MR27V1652D operates asynchronously, external clocks are not required, making this device easy-to-use. The MR27V1652D is suitable as large-capacity fixed memory for microcomputers and data terminals. It is manufactured using a CMOS double silicon gate technology and is offered in 42-pin DIP, 44-pin SOP, 44-pin TSOP or 48-pin TSOP packages.

### FEATURES

- 1,048,576 word x 16bit / 2,097,152 word x 8bit electrically switchable configuration
- Single +3.3V power supply
- Access time 80ns  
Page mode access time 30ns
- Input / Output TTL compatible
- Three-state output
- Packages

42-pin plastic DIP (DIP42-P-600-2.54) (Product name : MR27V1652D-xxRA)  
44-pin plastic SOP (SOP44-P-600-1.27-K) (Product name : MR27V1652D-xxMA)  
44-pin plastic TSOP (TSOP II 44-P-400-0.80-K) (Product name : MR27V1652D-xxTP)  
48-pin plastic TSOP (TSOP II 48-P-550-0.80-K) (Product name : MR27V1652D-xxTA)

## PIN CONFIGURATION (TOP VIEW)

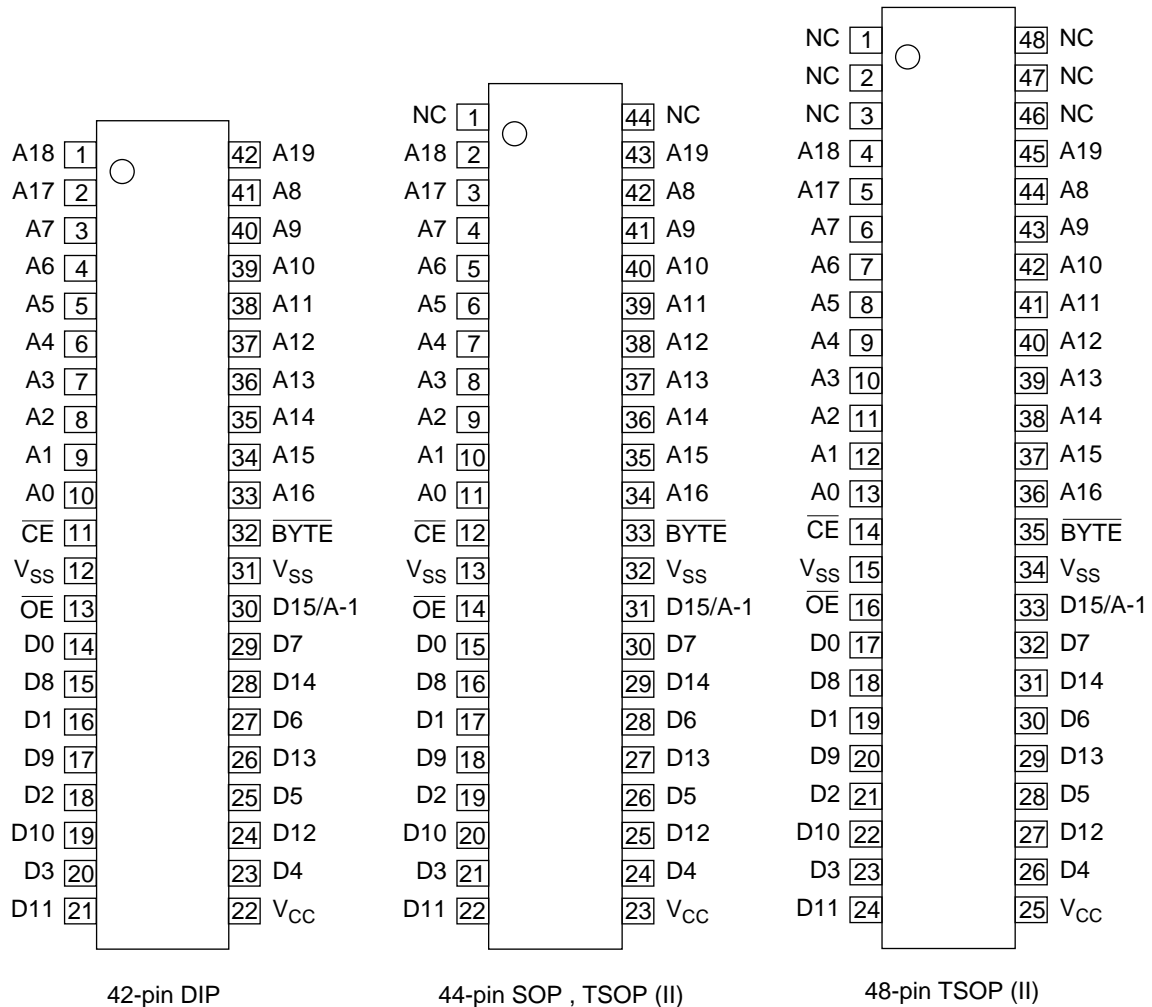

PIN NAMES	FUNCTIONS
D15/A-1	Data output / Address input
A0 - A19	Address input
D0 - D14	Data output
$\overline{CE}$	Chip enable
$\overline{OE}$	Output enable
$V_{CC}$	Power supply voltage
$V_{SS}$	GND
BYTE	Mode switch
NC	Non connection

## BLOCK DIAGRAM

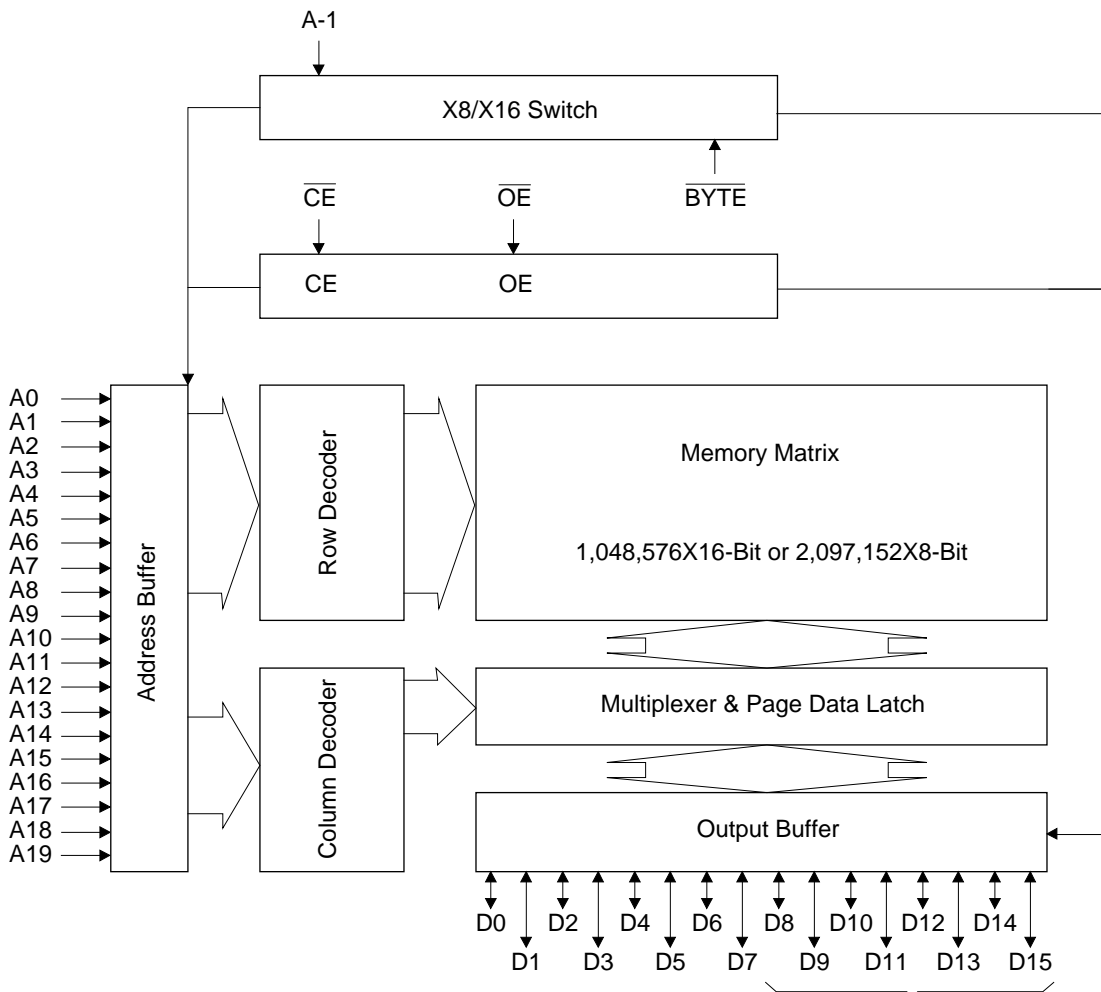

In 8-bit output mode, these pins are three-stated and pin D15 functions as the A-1 address pin.

## FUNCTION TABLE

MODE	$\overline{CE}$	$\overline{OE}$	$\overline{BYTE}$	$V_{CC}$	D0 - D7	D8 - D14	D15/A-1
READ (16-Bit)	L	L	H	3.3V	$D_{OUT}$		
READ (8-Bit)	L	L	L		$D_{OUT}$	Hi-Z	L/H
OUTPUT DISABLE	L	H	H		Hi-Z		*
			L		Hi-Z		*
STAND-BY	H	*	H	Hi-Z		*	
			L	Hi-Z		*	

\* : Don't Care

**ABSOLUTE MAXIMUM RATINGS**

Parameter	Symbol	Condition	Value	Unit
Operating temperature under bias	$T_{opr}$	-	0 to 70	°C
Storage temperature	$T_{stg}$		-55 to 125	°C
Input voltage	$V_I$	relative to $V_{SS}$	-0.5 to $V_{CC} + 0.5$	V
Output voltage	$V_O$		-0.5 to $V_{CC} + 0.5$	V
Power supply voltage	$V_{CC}$		-0.5 to 5	V
Power dissipation per package	$P_D$	-	1.0	W

**RECOMMENDED OPERATING CONDITIONS FOR READ**

(Ta=0 to 70°C)

Parameter	Symbol	Condition	Min.	Typ.	Max.	Unit
$V_{CC}$ power supply voltage	$V_{CC}$	$V_{CC}=3.0V-3.6V$	3.0	-	3.6	V
Input "H" level	$V_{IH}$		2.2	-	$V_{CC}+0.5^*$	V
Input "L" level	$V_{IL}$		-0.5**	-	0.6	V

Voltage is relative to Vss

\* :  $V_{CC}+1.5V$  (Max.) when pulse width of overshoot is less than 10nS.

\*\* : -1.5V (Min.) when pulse width of undershoot is less than 10nS.

**ELECTRICAL CHARACTERISTICS (Read operation)****DC Characteristics**(V<sub>CC</sub>=3.3V±0.3V, T<sub>a</sub>=0 to 70°C)

Parameter	Symbol	Condition	Min.	Typ.	Max.	Unit
Input leakage current	I <sub>LI</sub>	V <sub>I</sub> =0 to V <sub>CC</sub>	-	-	10	μA
Output leakage current	I <sub>LO</sub>	V <sub>O</sub> =0 to V <sub>CC</sub>	-	-	10	μA
V <sub>CC</sub> power supply current (Standby)	I <sub>CS1</sub>	$\overline{CE}=V_{CC}$	-	-	50	μA
	I <sub>CS2</sub>	$\overline{CE}=V_{IH}$	-	-	1	mA
V <sub>CC</sub> power supply current (Read)	I <sub>CCA</sub>	$\overline{CE}=V_{IL}$ , $\overline{OE}=V_{IH}$ tc=80ns	-	-	100	mA
Input "H" level	V <sub>IH</sub>	-	2.2	-	V <sub>CC</sub> +0.5*	V
Input "L" level	V <sub>IL</sub>	-	-0.5**	-	0.6	V
Output "H" level	V <sub>OH</sub>	I <sub>OH</sub> =-400μA	2.4	-	-	V
Output "L" level	V <sub>OL</sub>	I <sub>OL</sub> =2.1mA	-	-	0.4	V

Voltage is relative to V<sub>SS</sub>\* : V<sub>CC</sub>+1.5V (Max.) when pulse width of overshoot is less than 10nS.

\*\* : -1.5V (Min.) when pulse width of undershoot is less than 10nS.

**AC Characteristics**(V<sub>CC</sub>=3.3V±0.3V, T<sub>a</sub>=0 to 70°C)

Parameter	Symbol	Condition	Min.	Max.	Unit
Address access cycle time	T <sub>C</sub>	-	80	-	ns
Address access time	T <sub>ACC</sub>	$\overline{CE}=\overline{OE}=V_{IL}$	-	80	ns
Page access cycle time	T <sub>PC</sub>	-	30	-	ns
Page access time	T <sub>PAC</sub>	-	-	30	ns
$\overline{CE}$ access time	T <sub>CE</sub>	$\overline{OE}=V_{IL}$	-	80	ns
$\overline{OE}$ access time	T <sub>OE</sub>	$\overline{CE}=V_{IL}$	-	40	ns
Output disable time	T <sub>CHZ</sub>	$\overline{OE}=V_{IL}$	0	30	ns
	T <sub>OHZ</sub>	$\overline{CE}=V_{IL}$	0	25	ns
Output hold time	T <sub>OH</sub>	$\overline{CE}=\overline{OE}=V_{IL}$	0	-	ns

**Measurement conditions**

Input signal level	-----	0V/3V
Input timing reference level	-----	0.8V/2.0V
Output load	-----	100pF
Output timing reference level	-----	0.8V/2.0V

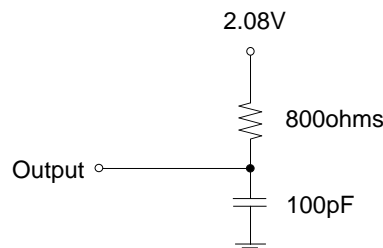

## TIMING CHART

## NORMAL MODE READ CYCLE

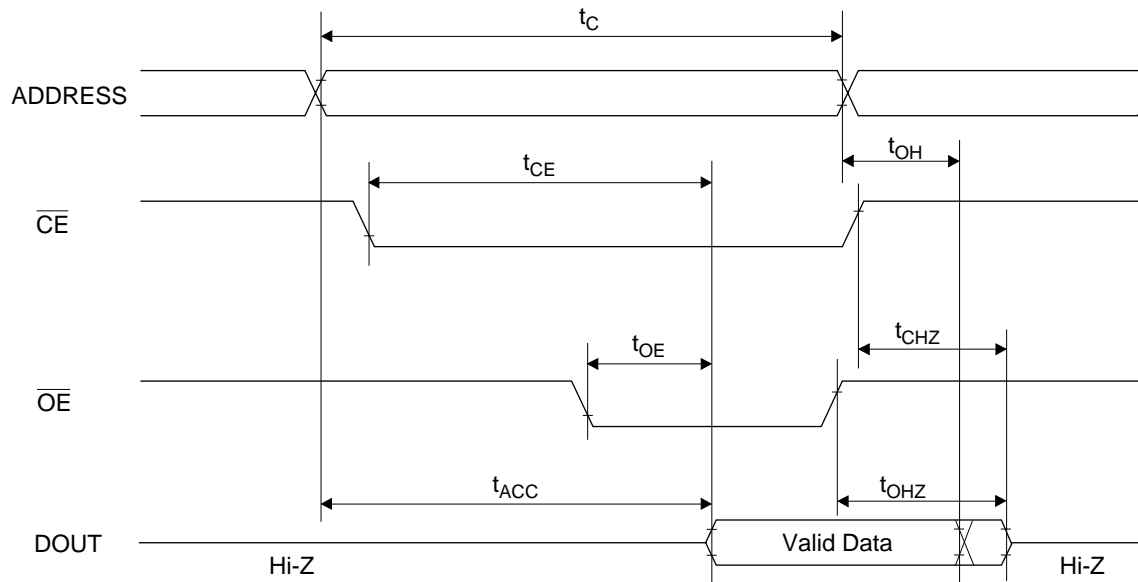

## PAGE MODE READ CYCLE

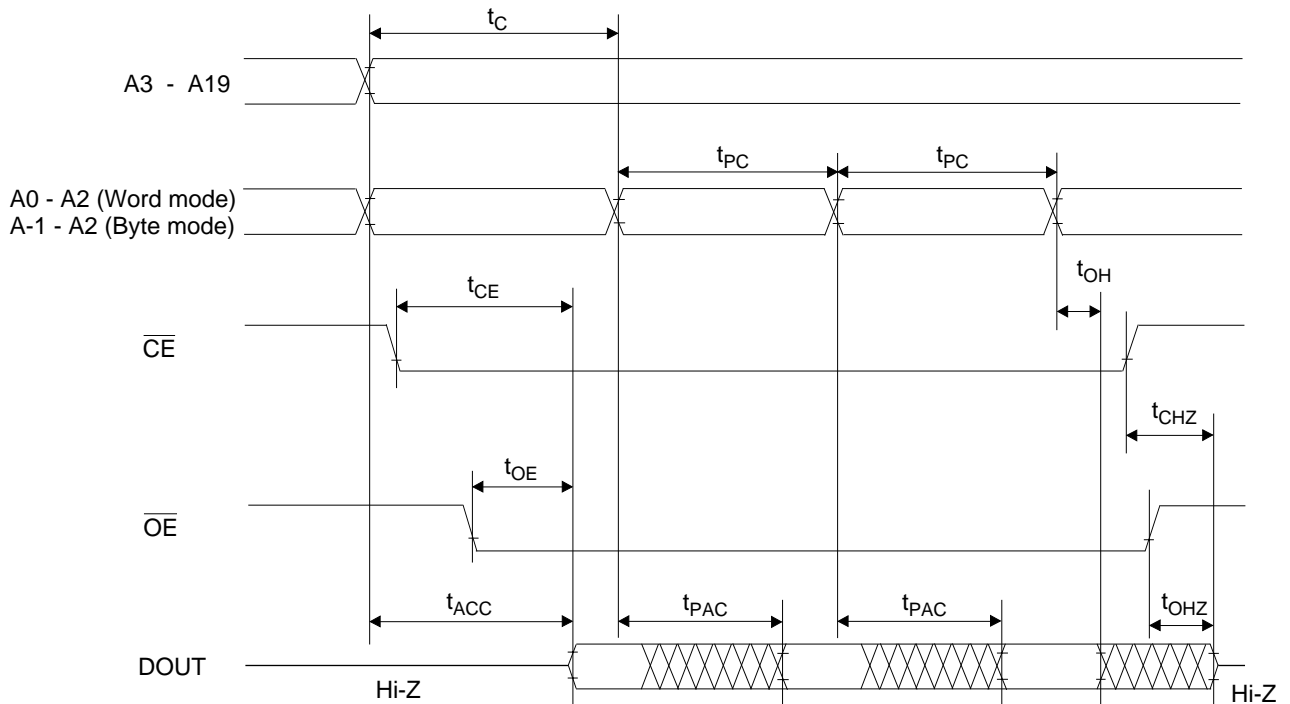

**PIN Capacitance**(V<sub>CC</sub>=3.3V, T<sub>a</sub>=25°C, f=1MHz)

Parameter	Symbol	Condition	Min.	Typ.	Max.	Unit
Input	C <sub>IN1</sub>	V <sub>I</sub> =0V	-	-	8 (10)	pF
$\overline{\text{BYTE}}$	C <sub>IN2</sub>		-	-	120	
Output	C <sub>OUT</sub>	V <sub>O</sub> =0V	-	-	10 (12)	

( ) : DIP only