

# OKI Semiconductor

1A

## MR27V402D

262,144-Word x 16-Bit or 524,288-Word x 8-Bit One Time PROM

### DESCRIPTION

The MR27V402D is a 4Mbit electrically Programmable Read-Only Memory whose configuration can be electrically switched between 262,144 word x 16bit and 524,288 word x 8bit. The MR27V402D operates on a single +3V-3.3V power supply and is TTL compatible. Since the MR27V402D operates asynchronously, external clocks are not required, making this device easy-to-use. The MR27V402D is suitable as large-capacity fixed memory for microcomputers and data terminals. It is manufactured using a CMOS double silicon gate technology and is offered in 40-pin DIP, 40-pin SOP or 44-pin TSOP packages.

### FEATURES

- 262,144 word x 16bit / 524,288 word x 8bit electrically switchable configuration
- Single +3V-3.3V power supply
- Access time
  - 100ns access time ( $V_{cc}=+3V$ )
  - 80ns access time ( $V_{cc}=+3.3V$ )
- Input / Output TTL compatible
- Three-state output
- Packages
  - 40-pin plastic DIP (DIP40-P-600-2.54) (Product name : MR27V402DRP)
  - 40-pin plastic SOP (SOP40-P-525-1.27-K) (Product name : MR27V402DMP)
  - 44-pin plastic TSOP (TSOP II 44-P-400-0.80-K) (Product name : MR27V402DTP)

## PIN CONFIGURATION (TOP VIEW)

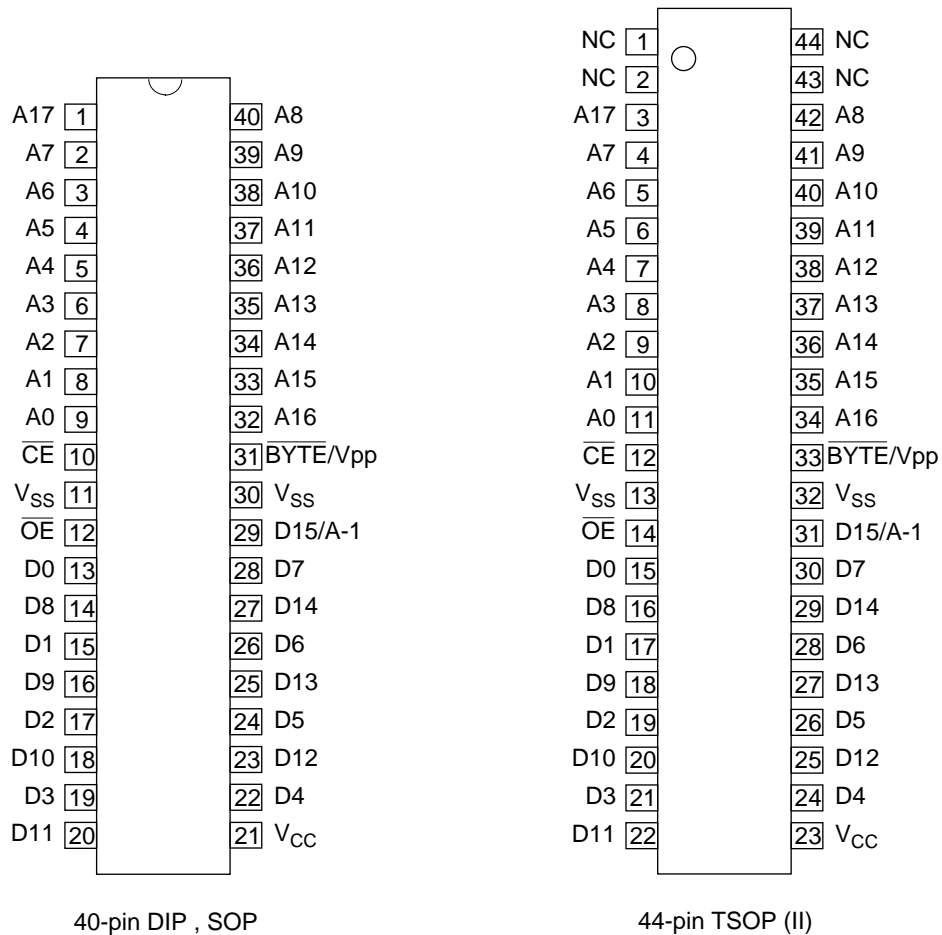

PIN NAMES	FUNCTIONS
D15/A-1	Data output / Address input
A0-A17	Address input
D0-D14	Data output
$\overline{\text{CE}}$	Chip enable
$\overline{\text{OE}}$	Output enable
V <sub>CC</sub>	Power supply voltage
V <sub>SS</sub>	GND
BYTE/V <sub>PP</sub>	Mode switch / Program power supply voltage
NC	Non connection

## BLOCK DIAGRAM

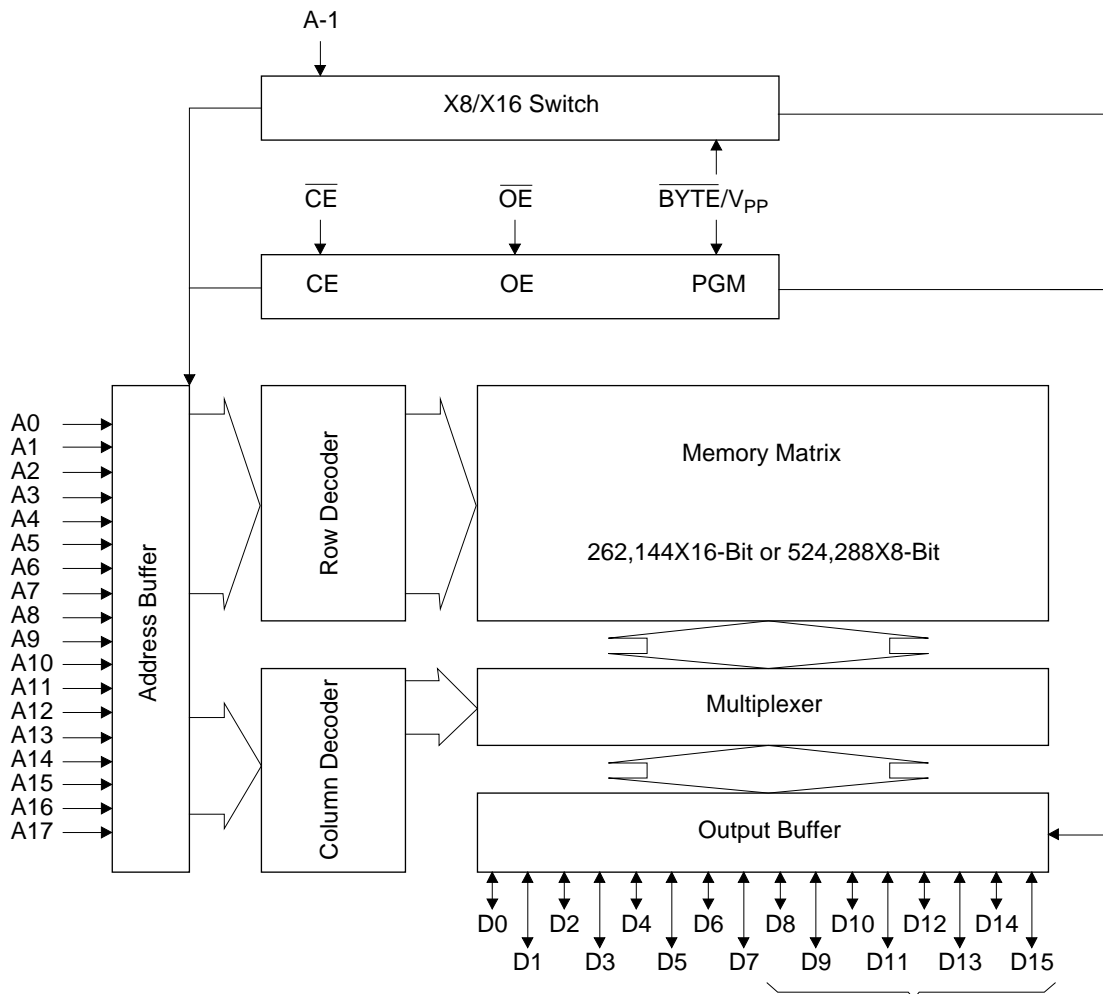

In 8-bit output mode, these pins are three-stated and pin D15 functions as the A-1 address pin.

## FUNCTION TABLE

MODE	$\overline{CE}$	$\overline{OE}$	BYTE/ $V_{PP}$	$V_{CC}$	D0 - D7	D8 - D14	D15/A-1
READ (16-Bit)	L	L	H	3.0V to 3.3V	$D_{OUT}$		
READ (8-Bit)	L	L	L		$D_{OUT}$	Hi-Z	L/H
OUTPUT DISABLE	L	H	H		Hi-Z		*
			L		Hi-Z		*
STAND-BY	H	*	H	Hi-Z		*	
			L	Hi-Z		*	
PROGRAM	L	H	9.75V	$D_{IN}$			
PROGRAM INHIBIT	H	H		Hi-Z			
PROGRAM VERIFY	H	L		$D_{OUT}$			

\*: Don't Care

**ABSOLUTE MAXIMUM RATINGS**

Parameter	Symbol	Condition	Value	Unit
Operating temperature under bias	$T_{opr}$	-	0 to 70	°C
Storage temperature	$T_{stg}$		-55 to 125	°C
Input voltage	$V_I$	relative to $V_{SS}$	-0.5 to $V_{CC} + 0.5$	V
Output voltage	$V_O$		-0.5 to $V_{CC} + 0.5$	V
Power supply voltage	$V_{CC}$		-0.5 to 5	V
Program power supply voltage	$V_{PP}$		-0.5 to 11.5	V
Power dissipation per package	$P_D$	-	1.0	W

**RECOMMENDED OPERATING CONDITIONS**

(Ta=0 to 70°C)

Parameter	Symbol	Condition	Min.	Typ.	Max.	Unit
$V_{CC}$ power supply voltage	$V_{CC}$	$V_{CC}=2.7V-3.6V$	2.7	-	3.6	V
$V_{PP}$ power supply voltage	$V_{PP}$		-0.5	-	$V_{CC}+0.5$	V
Input "H" level	$V_{IH}$		2.2	-	$V_{CC}+0.5^*$	V
Input "L" level	$V_{IL}$		-0.5**	-	0.6	V

Voltage is relative to  $V_{SS}$ \* :  $V_{CC}+1.5V$  (Max.) when pulse width of overshoot is less than 10nS.

\*\* : -1.5V (Min.) when pulse width of undershoot is less than 10nS.

## ELECTRICAL CHARACTERISTICS (Read operation)

### DC Characteristics 1

( $V_{CC}=3V\pm 0.3V$ ,  $T_a=0$  to  $70^{\circ}C$ )

Parameter	Symbol	Condition	Min.	Typ.	Max.	Unit
Input leakage current	$I_{LI}$	$V_I=0$ to $V_{CC}$	-	-	10	$\mu A$
Output leakage current	$I_{LO}$	$V_O=0$ to $V_{CC}$	-	-	10	$\mu A$
$V_{CC}$ power supply current (Standby)	$I_{CCSC}$	$\overline{CE}=V_{CC}$	-	-	50	$\mu A$
	$I_{CCST}$	$\overline{CE}=V_{IH}$	-	-	1	mA
$V_{CC}$ power supply current (Read)	$I_{CCA}$	$\overline{CE}=V_{IL}$ , $\overline{OE}=V_{IH}$ $t_c=100ns$	-	-	25	mA
$V_{PP}$ power supply current	$I_{PP}$	$V_{PP}=V_{CC}$	-	-	10	$\mu A$
Input "H" level	$V_{IH}$	-	2.2	-	$V_{CC}+0.5^*$	V
Input "L" level	$V_{IL}$	-	-0.5**	-	0.6	V
Output "H" level	$V_{OH}$	$I_{OH}=-400\mu A$	2.4	-	-	V
Output "L" level	$V_{OL}$	$I_{OL}=2.1mA$	-	-	0.4	V

Voltage is relative to  $V_{SS}$

\* :  $V_{CC}+1.5V$  (Max.) when pulse width of overshoot is less than 10nS.

\*\* : -1.5V (Min.) when pulse width of undershoot is less than 10nS.

### DC Characteristics 2

( $V_{CC}=3.3V\pm 0.3V$ ,  $T_a=0$  to  $70^{\circ}C$ )

Parameter	Symbol	Condition	Min.	Typ.	Max.	Unit
Input leakage current	$I_{LI}$	$V_I=0$ to $V_{CC}$	-	-	10	$\mu A$
Output leakage current	$I_{LO}$	$V_O=0$ to $V_{CC}$	-	-	10	$\mu A$
$V_{CC}$ power supply current (Standby)	$I_{CCSC}$	$\overline{CE}=V_{CC}$	-	-	50	$\mu A$
	$I_{CCST}$	$\overline{CE}=V_{IH}$	-	-	1	mA
$V_{CC}$ power supply current (Read)	$I_{CCA}$	$\overline{CE}=V_{IL}$ , $\overline{OE}=V_{IH}$ $t_c=80ns$	-	-	30	mA
$V_{PP}$ power supply current	$I_{PP}$	$V_{PP}=V_{CC}$	-	-	10	$\mu A$
Input "H" level	$V_{IH}$	-	2.2	-	$V_{CC}+0.5^*$	V
Input "L" level	$V_{IL}$	-	-0.5**	-	0.6	V
Output "H" level	$V_{OH}$	$I_{OH}=-400\mu A$	2.4	-	-	V
Output "L" level	$V_{OL}$	$I_{OL}=2.1mA$	-	-	0.4	V

Voltage is relative to  $V_{SS}$

\* :  $V_{CC}+1.5V$  (Max.) when pulse width of overshoot is less than 10nS.

\*\* : -1.5V (Min.) when pulse width of undershoot is less than 10nS.

**AC Characteristics 1** $(V_{CC}=3V\pm 0.3V, T_a=0 \text{ to } 70^\circ\text{C})$ 

Parameter	Symbol	Condition	Min.	Max.	Unit
Address cycle time	$T_C$	-	100	-	ns
Address access time	$T_{ACC}$	$\overline{CE}=\overline{OE}=V_{IL}$	-	100	ns
$\overline{CE}$ access time	$T_{CE}$	$\overline{OE}=V_{IL}$	-	100	ns
$\overline{OE}$ access time	$T_{OE}$	$\overline{CE}=V_{IL}$	-	50	ns
Output disable time	$T_{CHZ}$	$\overline{OE}=V_{IL}$	0	30	ns
	$T_{OHZ}$	$\overline{CE}=V_{IL}$	0	25	ns
Output hold time	$T_{OH}$	$\overline{CE}=\overline{OE}=V_{IL}$	0	-	ns

## Measurement conditions

Input signal level	-----	0V/3V
Input timing reference level	-----	0.8V/2.0V
Output load	-----	50pF
Output timing reference level	-----	0.8V/2.0V

**AC Characteristics 2** $(V_{CC}=3.3V\pm 0.3V, T_a=0 \text{ to } 70^\circ\text{C})$ 

Parameter	Symbol	Condition	Min.	Max.	Unit
Address cycle time	$T_C$	-	80	-	ns
Address access time	$T_{ACC}$	$\overline{CE}=\overline{OE}=V_{IL}$	-	80	ns
$\overline{CE}$ access time	$T_{CE}$	$\overline{OE}=V_{IL}$	-	80	ns
$\overline{OE}$ access time	$T_{OE}$	$\overline{CE}=V_{IL}$	-	40	ns
Output disable time	$T_{CHZ}$	$\overline{OE}=V_{IL}$	0	30	ns
	$T_{OHZ}$	$\overline{CE}=V_{IL}$	0	25	ns
Output hold time	$T_{OH}$	$\overline{CE}=\overline{OE}=V_{IL}$	0	-	ns

## Measurement conditions

Input signal level	-----	0V/3V
Input timing reference level	-----	0.8V/2.0V
Output load	-----	50pF
Output timing reference level	-----	0.8V/2.0V

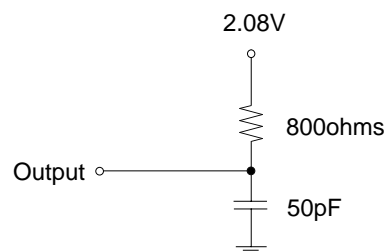

## TIMING CHART (READ CYCLE)

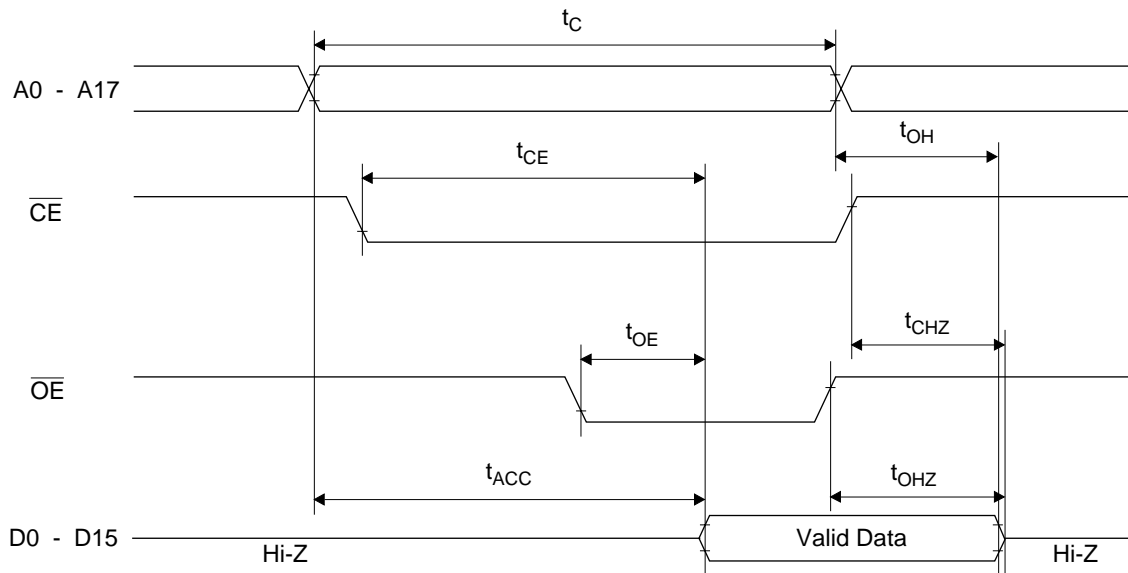
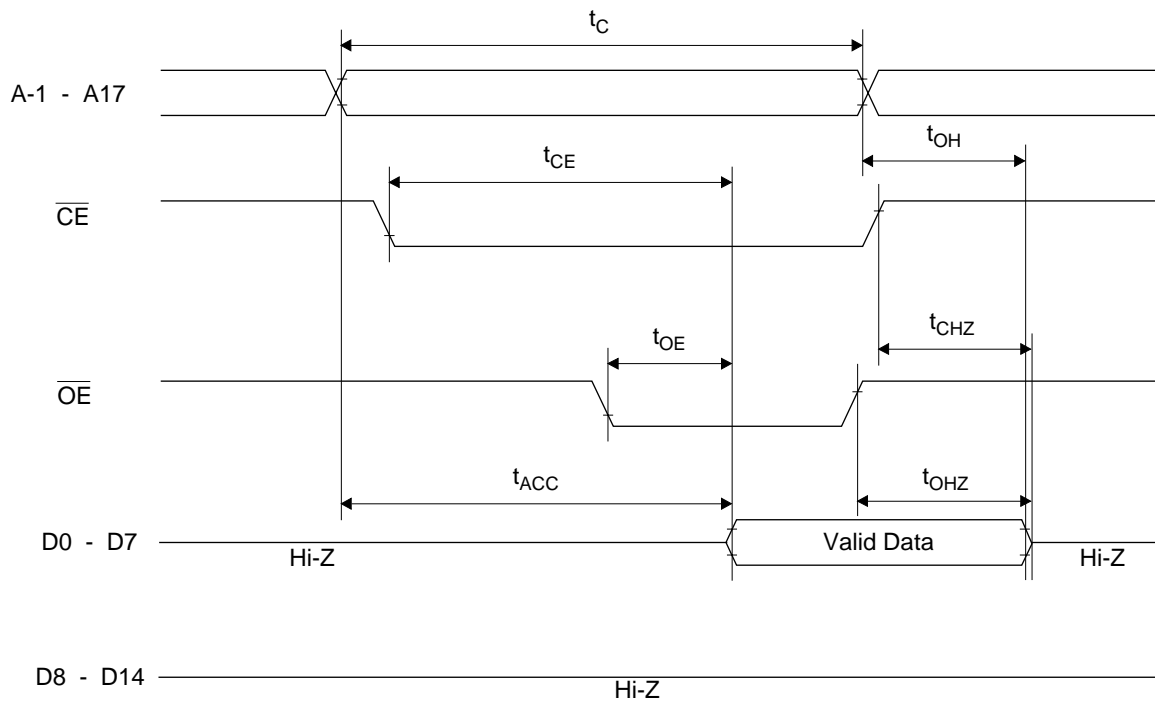
16-Bit Read Mode ( $\overline{\text{BYTE}}=\text{V}_{\text{IH}}$ )8-Bit Read Mode ( $\overline{\text{BYTE}}=\text{V}_{\text{IL}}$ )

## ELECTRICAL CHARACTERISTICS (Programming operation)

### DC Characteristics

(Ta=25°C±5°C)

Parameter	Symbol	Condition	Min.	Typ.	Max.	Unit
Input leakage current	I <sub>LI</sub>	V <sub>I</sub> =V <sub>CC</sub> +0.5V	-	-	10	μA
V <sub>PP</sub> power supply current (Program)	I <sub>PP2</sub>	$\overline{CE}=V_{IL}$	-	-	50	mA
V <sub>CC</sub> power supply current	I <sub>CC</sub>	-	-	-	50	mA
Input "H" level	V <sub>IH</sub>	-	3.0	-	V <sub>CC</sub> +0.5	V
Input "L" level	V <sub>IL</sub>	-	-0.5	-	0.8	V
Output "H" level	V <sub>OH</sub>	I <sub>OH</sub> =-400μA	2.4	-	-	V
Output "L" level	V <sub>OL</sub>	I <sub>OL</sub> =2.1mA	-	-	0.45	V
Program voltage	V <sub>PP</sub>	-	9.5	9.75	10.0	V
V <sub>CC</sub> power supply voltage	V <sub>CC</sub>	-	3.9	4.0	4.1	V

Voltage is relative to Vss

### AC Characteristics

(V<sub>CC</sub>=4.0V±0.1V, V<sub>pp</sub>=9.75V±0.25V, Ta=25°C±5°C)

Parameter	Symbol	Condition	Min.	Typ.	Max.	Unit
Address set-up time	T <sub>AS</sub>	-	100	-	-	ns
$\overline{OE}$ set-up time	T <sub>OES</sub>	-	2	-	-	μs
Data set-up time	T <sub>DS</sub>	-	100	-	-	ns
Address hold time	T <sub>AH</sub>	-	2	-	-	μs
Data hold time	T <sub>DH</sub>	-	100	-	-	ns
Output float delay from $\overline{OE}$	T <sub>OHZ</sub>	-	0	-	100	ns
V <sub>PP</sub> voltage set-up time	T <sub>VS</sub>	-	2	-	-	μs
Program pulse width	T <sub>PW</sub>	-	9	10	11	μs
Data valid from $\overline{OE}$	T <sub>OE</sub>	-	-	-	100	ns
Address hold from $\overline{OE}$ high	T <sub>AHO</sub>	-	0	-	-	ns

### Pin Check Function

Pin Check Function is to check contact between each device-pin and each socket-lead with EPROM programmer.

Setting up address as the following condition call the preprogrammed codes on device outputs.

(V<sub>CC</sub>=3.3V±0.3V,  $\overline{CE}=\overline{OE}=V_{IL}$ ,  $\overline{BYTE}/V_{pp}=V_{IH}$ , Ta=25°C±5°C)

A0	A1	A2	A3	A4	A5	A6	A7	A8	A9	A10	A11	A12	A13	A14	A15	A16	A17	DATA
0	1	0	1	0	1	0	1	0	VH*	0	1	0	1	0	1	0	0	FF00
1	0	1	0	1	0	1	0	1	VH*	1	0	1	0	1	0	1	1	00FF
Other conditions																		FFFF

\*: VH=8V±0.25V

### Consecutive Programming Waveforms

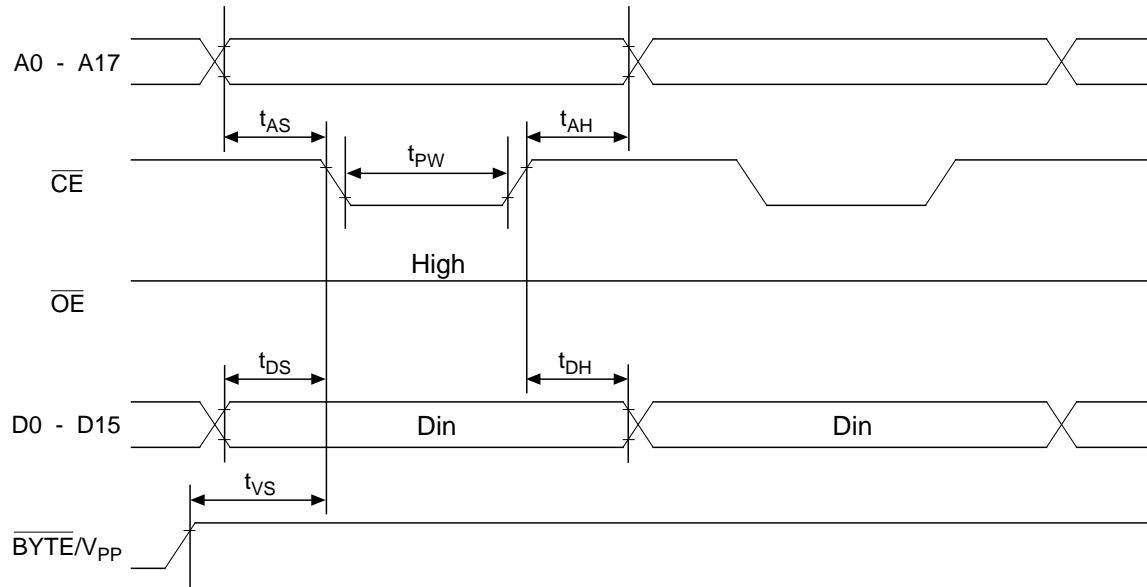

### Consecutive Program Verify Waveforms

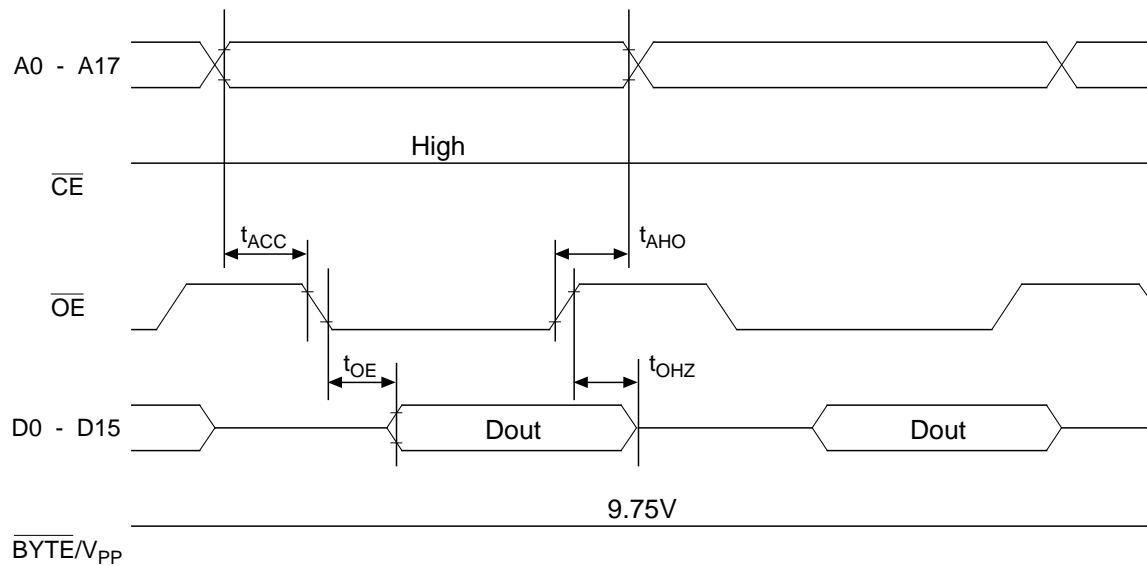

### Program and Program Verify Cycle Waveforms

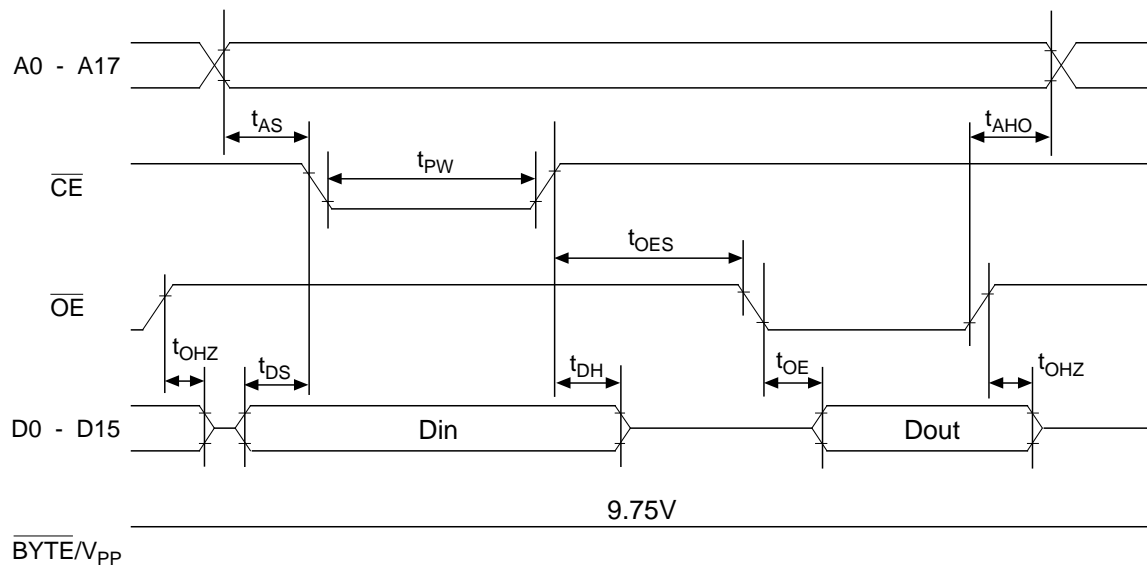

### PIN Capacitance

( $V_{CC}=3.3V$ ,  $T_a=25^\circ C$ ,  $f=1MHz$ )

Parameter	Symbol	Condition	Min.	Typ.	Max.	Unit
Input	$C_{IN1}$	$V_I=0V$	-	-	8 (10)	pF
$\overline{BYTE/V_{PP}}$	$C_{IN2}$		-	-	60	
Output	$C_{OUT}$	$V_O=0V$	-	-	10 (12)	

( ) : DIP only

## Programming / Verify Flow Chart

## Programming

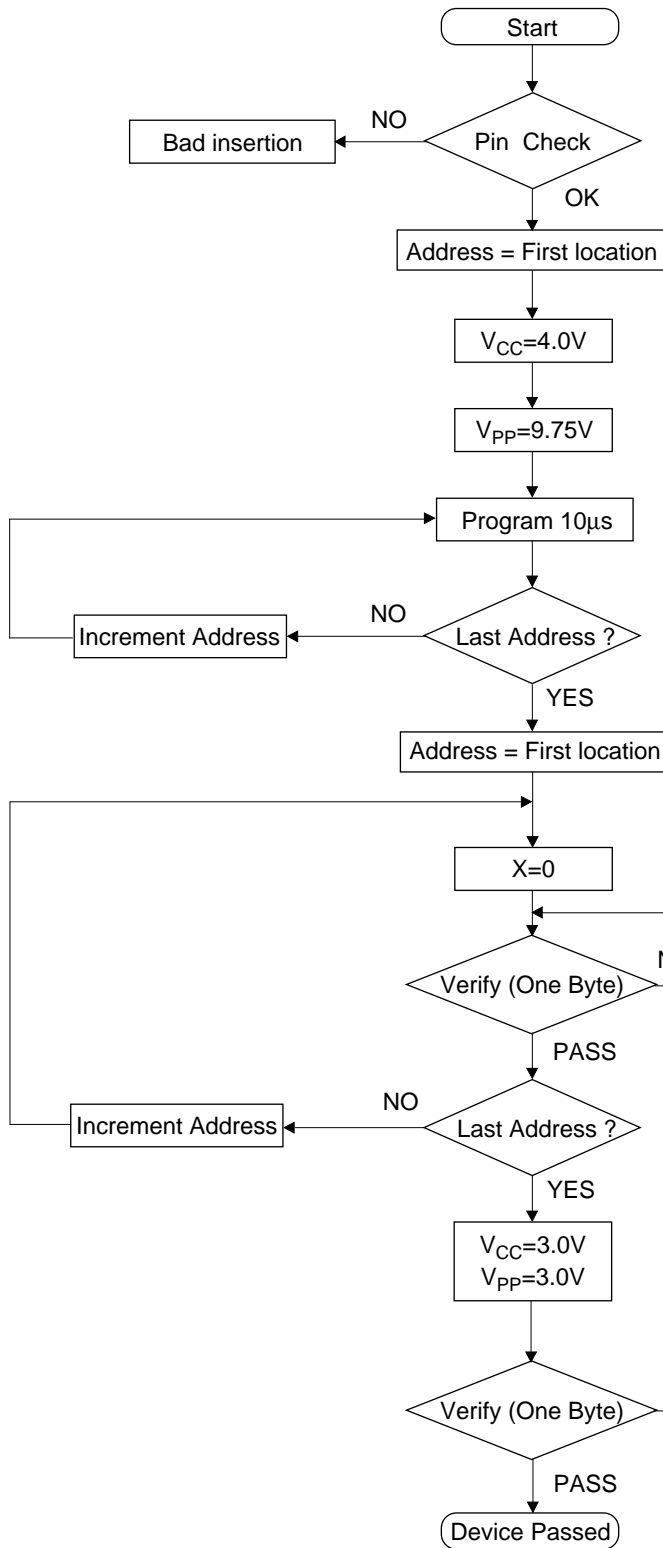

## Verify

