

OKI Semiconductor

FEDR27V1602E-02-03

Issue Date: July. 8, 2003

MR27V1602E

1,048,576-Word × 16-Bit or 2,097,152-Word × 8-Bit Production Programmed Read Only Memory (P2ROM)

GENERAL DESCRIPTION

The MR27V1602E is a 16 Mbit Production Programmed Read-Only Memory (P2ROM) that can be electrically switched between 1,048,576-word × 16-bit and 2,097,152-word × 8-bit by the state of the BYTE# pin. The MR27V1602E supports high speed asynchronous read operation using a single 3.3V power supply.

FEATURES

- 1,048,576-word × 16-bit/2,097,152-word × 8-bit electrically switchable configuration
- +3.3 V power supply
- Access time 90 nS MAX
- Operating current 30 mA MAX
- Standby current 50 μA MAX
- Input/Output TTL compatible
- Three-state output
- Packages:

44-pin plastic SOP (SOP44-P-600-1.27-K) (Product Name : MR27V1602E-xxxMA)
44-pin plastic TSOP (TSOP II 44-P-400-0.80-K) (Product Name : MR27V1602E-xxxTP)
48-pin plastic TSOP (TSOP I 48-P-1220-0.50-1K) (Product Name : MR27V1602E-xxxTN)

PIN CONFIGURATION (TOP VIEW)

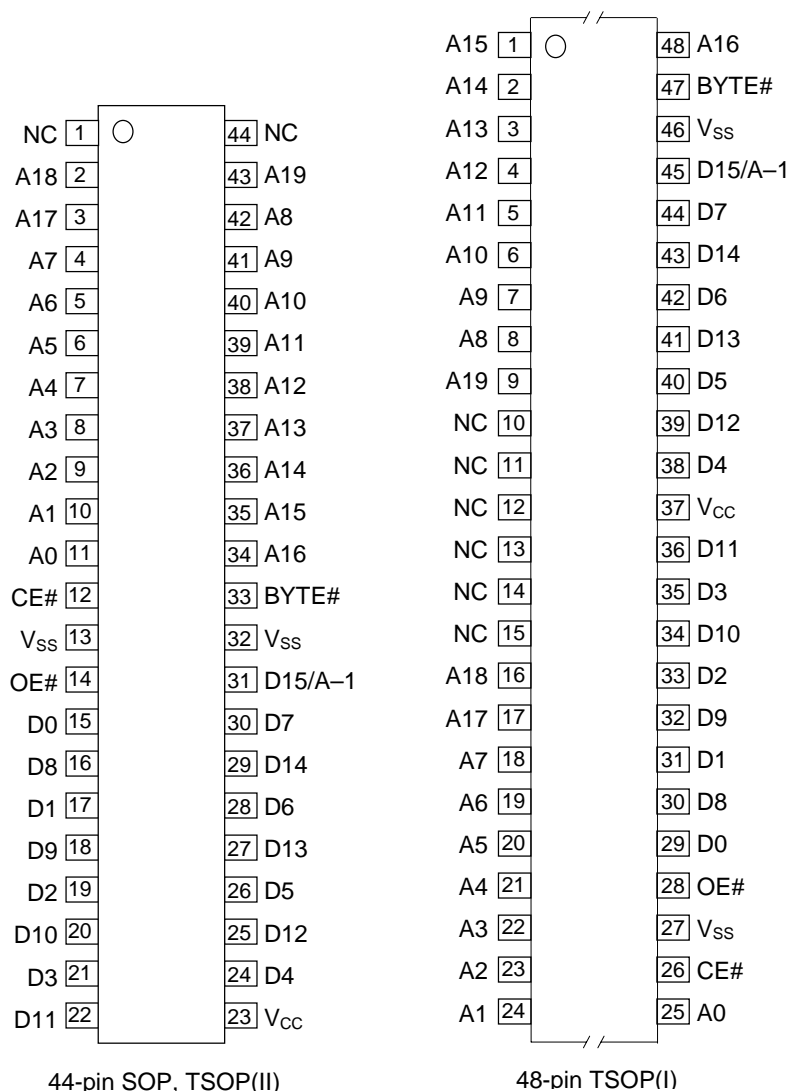

Pin name	Functions
D15/A-1	Data output/Address input
A0 to A19	Address input
D0 to D14	Data output
CE#	Chip enable
OE#	Output enable
BYTE#	Mode switch
V _{cc}	Power supply voltage
V _{ss}	GND
NC	Non connection

BLOCK DIAGRAM

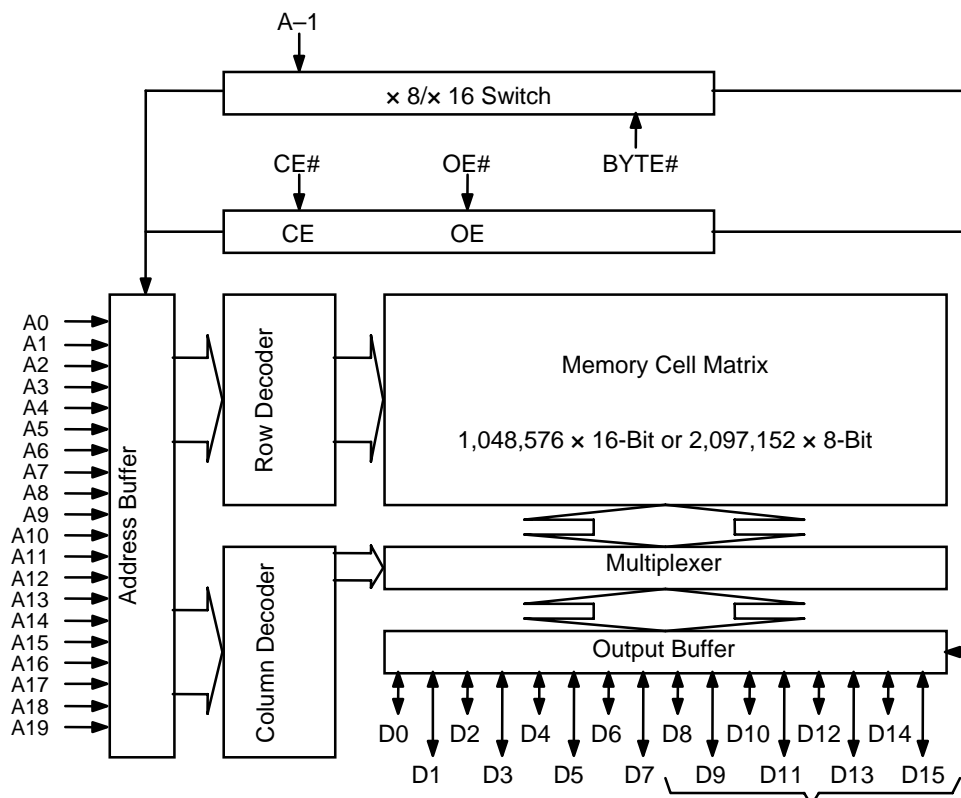

In 8-bit output mode, these pins are placed in a high-Z state and pin D15 functions as the A-1 address pin.

FUNCTION TABLE

Mode	CE#	OE#	BYTE#	V _{CC}	D0 to D7	D8 to D14	D15/A-1
Read (16-Bit)	L	L	H	3.3 V	D _{OUT}		
Read (8-Bit)	L	L	L		D _{OUT}	Hi-Z	L/H
Output disable	L	H	H		Hi-Z		*
			L		Hi-Z		*
Standby	H	*	H		Hi-Z		*
			L		Hi-Z		*

*: Don't Care (H or L)

ABSOLUTE MAXIMUM RATINGS

Parameter	Symbol	Condition	Value	Unit
Operating temperature under bias	T _a	—	0 to 70	°C
Storage temperature	T _{stg}		-55 to 125	°C
Input voltage	V _I	relative to V _{SS}	-0.5 to V _{CC} +0.5	V
Output voltage	V _O		-0.5 to V _{CC} +0.5	V
Power supply voltage	V _{CC}		-0.5 to 5	V
Power dissipation per package	P _D	—	1.0	W

RECOMMENDED OPERATING CONDITIONS(T_a = 0 to 70°C)

Parameter	Symbol	Condition	Min.	Typ.	Max.	Unit
V _{CC} power supply voltage	V _{CC}	V _{CC} = 3.0 to 3.6 V	3.0	—	3.6	V
Input "H" level	V _{IH}		2.2	—	V _{CC} +0.5*	V
Input "L" level	V _{IL}		-0.5**	—	0.6	V

Voltage is relative to V_{SS}.* : V_{CC}+1.5V(Max.) when pulse width of overshoot is less than 10ns.

** : -1.5V(Min.) when pulse width of undershoot is less than 10ns.

ELECTRICAL CHARACTERISTICS

DC Characteristics

($V_{CC} = 3.3 \text{ V} \pm 0.3 \text{ V}$, $T_a = 0 \text{ to } 70^\circ\text{C}$)

parameter	Symbol	Condition	Min.	Typ.	Max.	Unit
Input leakage current	I_{LI}	$V_I = 0 \text{ to } V_{CC}$	—	—	10	μA
Output leakage current	I_{LO}	$V_O = 0 \text{ to } V_{CC}$	—	—	10	μA
V_{CC} power supply current (Standby)	I_{CCSC}	$CE\# = V_{CC}$	—	—	50	μA
	I_{CCST}	$CE\# = V_{IH}$	—	—	1	mA
V_{CC} power supply current (Read)	I_{CCA}	$CE\# = V_{IL}$, $OE\# = V_{IH}$ $t_c = 90 \text{ ns}$	—	—	30	mA
Input "H" level	V_{IH}	—	2.2	—	$V_{CC} + 0.5^*$	V
Input "L" level	V_{IL}	—	-0.5**	—	0.6	V
Output "H" level	V_{OH}	$I_{OH} = -2 \text{ mA}$	2.4	—	—	V
Output "L" level	V_{OL}	$I_{OL} = 4 \text{ mA}$	—	—	0.4	V

Voltage is relative to V_{SS} .

* : $V_{CC} + 1.5\text{V}$ (Max.) when pulse width of overshoot is less than 10ns.

** : -1.5V (Min.) when pulse width of undershoot is less than 10ns.

AC Characteristics

($V_{CC} = 3.3 \text{ V} \pm 0.3 \text{ V}$, $T_a = 0 \text{ to } 70^\circ\text{C}$)

Parameter	Symbol	Condition	Min.	Max.	Unit
Address cycle time	t_c	—	90	—	ns
Address access time	t_{ACC}	$CE\# = OE\# = V_{IL}$	—	90	ns
CE# access time	t_{CE}	$OE\# = V_{IL}$	—	90	ns
OE# access time	t_{OE}	$CE\# = V_{IL}$	—	45	ns
Output disable time	t_{CHZ}	$OE\# = V_{IL}$	0	20	ns
	t_{OHZ}	$CE\# = V_{IL}$	0	20	ns
Output hold time	t_{OH}	$CE\# = OE\# = V_{IL}$	0	—	ns

Measurement conditions

Input signal level ----- 0 V/3 V
 Input timing reference level----- 0.8 V/2.0 V
 Output load ----- 100 pF
 Output timing reference level ----- 0.8 V/2.0 V

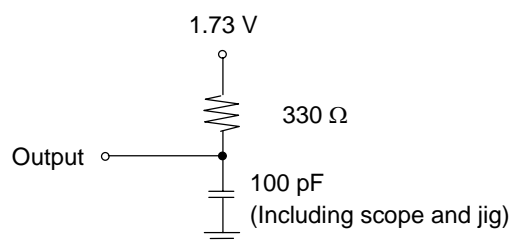

TIMING CHART (READ CYCLE)

16-BIT READ MODE (BYTE# = V_{IH})

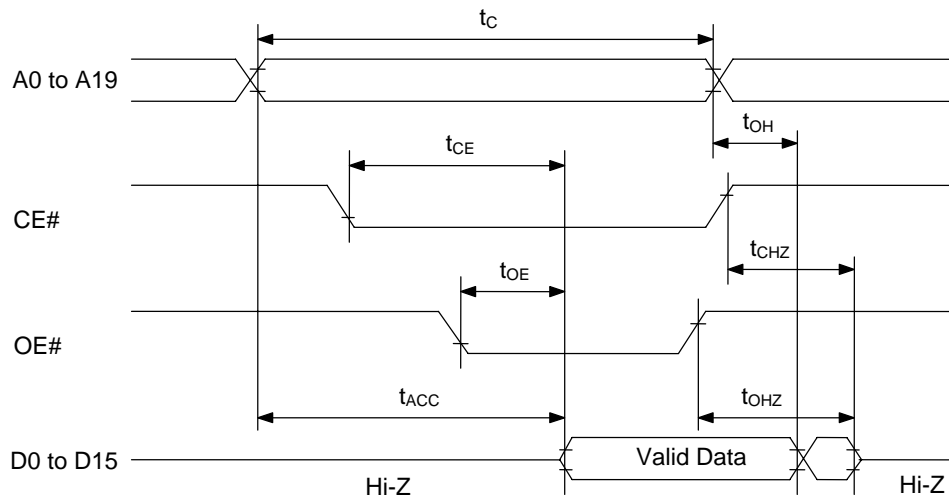

8-BIT READ MODE (BYTE# = V_{IL})

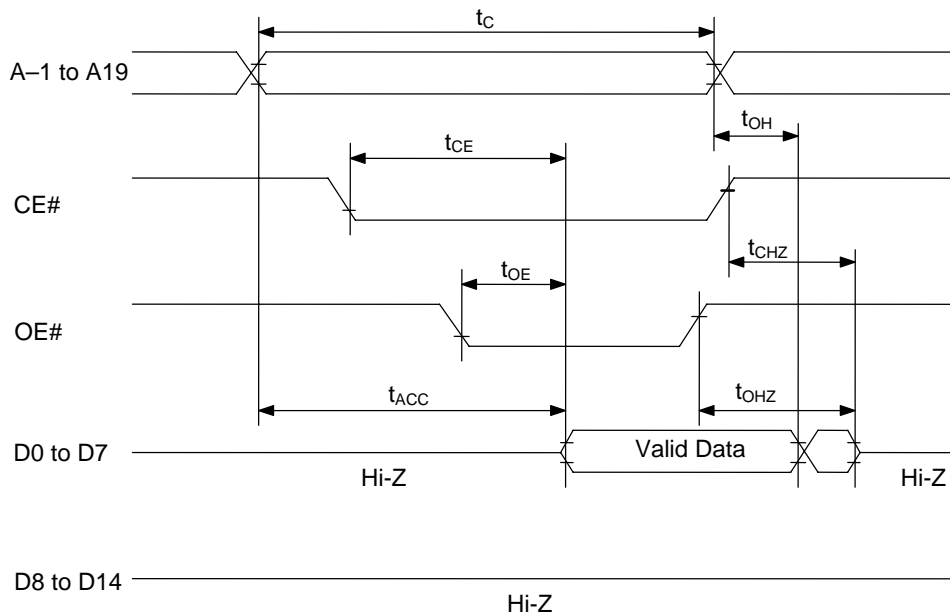

Pin Capacitance $(V_{CC} = 3.3 \text{ V}, T_a = 25^\circ\text{C}, f = 1 \text{ MHz})$

Parameter	Symbol	Condition	Min.	Typ.	Max.	Unit
Input	C_{IN1}	$V_I = 0 \text{ V}$	—	—	8	pF
BYTE#	C_{IN2}		—	—	120	
Output	C_{OUT}	$V_O = 0 \text{ V}$	—	—	10	

PACKAGE DIMENSIONS

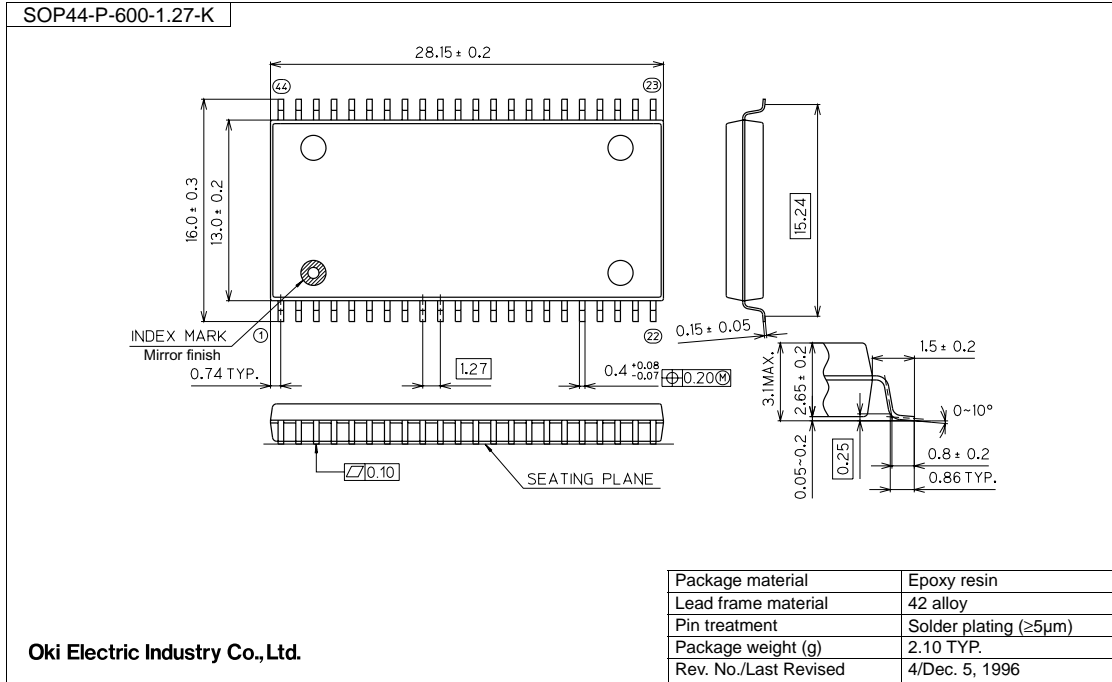

Notes for Mounting the Surface Mount Type Package

The surface mount type packages are very susceptible to heat in reflow mounting and humidity absorbed in storage.

Therefore, before you perform reflow mounting, contact Oki's responsible sales person for the product name, package name, pin number, package code and desired mounting conditions (reflow method, temperature and times).

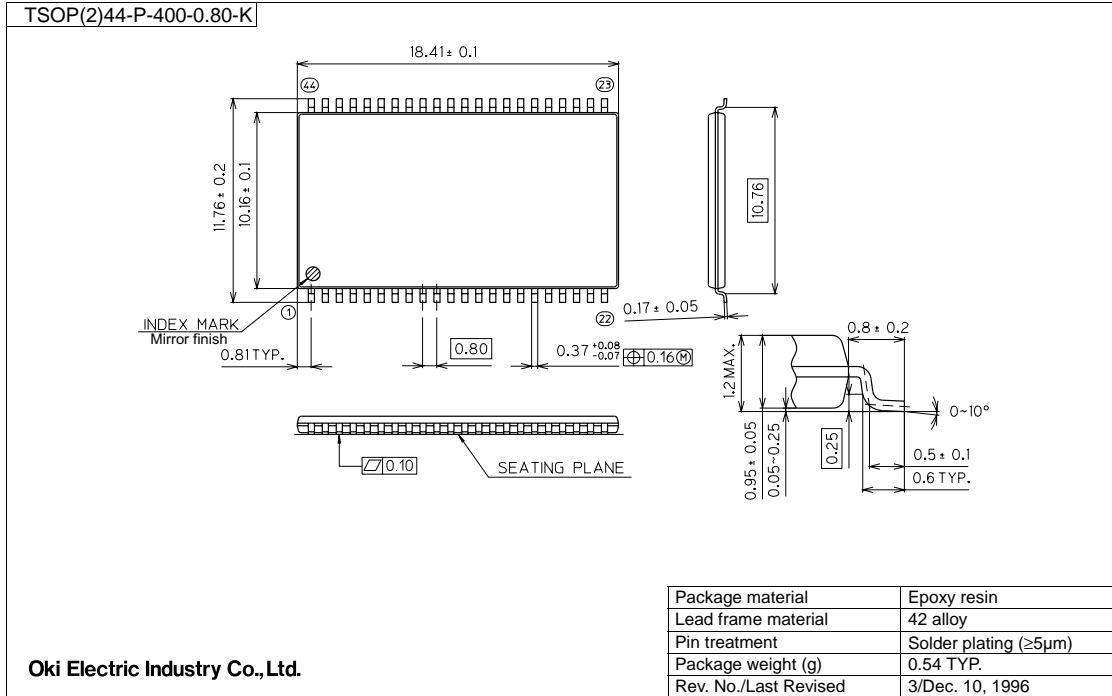

Notes for Mounting the Surface Mount Type Package

The surface mount type packages are very susceptible to heat in reflow mounting and humidity absorbed in storage.

Therefore, before you perform reflow mounting, contact Oki's responsible sales person for the product name, package name, pin number, package code and desired mounting conditions (reflow method, temperature and times).

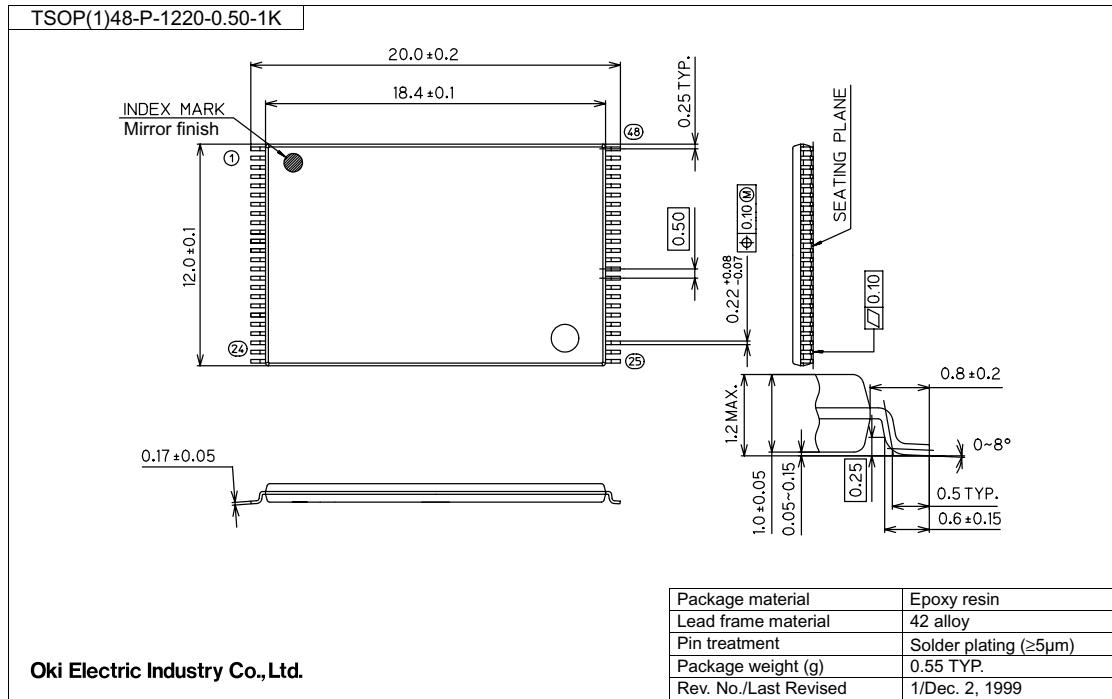

Notes for Mounting the Surface Mount Type Package

The surface mount type packages are very susceptible to heat in reflow mounting and humidity absorbed in storage.

Therefore, before you perform reflow mounting, contact Oki's responsible sales person for the product name, package name, pin number, package code and desired mounting conditions (reflow method, temperature and times).

REVISION HISTORY

Document No.	Date	Page		Description
		Previous Edition	Current Edition	
FEDR27V1602E-02-02	Jun 4, 2003	–	–	Final edition2
FEDR27V1602E-02-03	Jul 8, 2003	5	5	Change t_{CHZ} , t_{OHZ} to 20ns

NOTICE

1. The information contained herein can change without notice owing to product and/or technical improvements. Before using the product, please make sure that the information being referred to is up-to-date.
2. The outline of action and examples for application circuits described herein have been chosen as an explanation for the standard action and performance of the product. When planning to use the product, please ensure that the external conditions are reflected in the actual circuit, assembly, and program designs.
3. When designing your product, please use our product below the specified maximum ratings and within the specified operating ranges including, but not limited to, operating voltage, power dissipation, and operating temperature.
4. Oki assumes no responsibility or liability whatsoever for any failure or unusual or unexpected operation resulting from misuse, neglect, improper installation, repair, alteration or accident, improper handling, or unusual physical or electrical stress including, but not limited to, exposure to parameters beyond the specified maximum ratings or operation outside the specified operating range.
5. Neither indemnity against nor license of a third party's industrial and intellectual property right, etc. is granted by us in connection with the use of the product and/or the information and drawings contained herein. No responsibility is assumed by us for any infringement of a third party's right which may result from the use thereof.
6. The products listed in this document are intended for use in general electronics equipment for commercial applications (e.g., office automation, communication equipment, measurement equipment, consumer electronics, etc.). These products are not, unless specifically authorized by Oki, authorized for use in any system or application that requires special or enhanced quality and reliability characteristics nor in any system or application where the failure of such system or application may result in the loss or damage of property, or death or injury to humans.
Such applications include, but are not limited to, traffic and automotive equipment, safety devices, aerospace equipment, nuclear power control, medical equipment, and life-support systems.
7. Certain products in this document may need government approval before they can be exported to particular countries. The purchaser assumes the responsibility of determining the legality of export of these products and will take appropriate and necessary steps at their own expense for these.
8. No part of the contents contained herein may be reprinted or reproduced without our prior permission.

Copyright 2003 Oki Electric Industry Co., Ltd.