MSM6422

High speed and Simple 4-Bit Microcontroller

GENERAL DESCRIPTION

The MSM6422 is a low-power, single-chip device implemented in complementary metal-oxide semiconductor technology.

The MSM6422 can be used in place of logic ICs configured around a main CPU, or for small-scale systems such as home electronic equipment.

FEATURES

- ROM : 2048 words × 8 bits
 - RAM : 64 words × 4 bits
 - I/O port
 - Input-output port : 4 ports × 4 bits (pseudo bidirectional configuration)
1 port × 2 bits (pseudo bidirectional configuration)
 - Input port : 1 port × 1 bit (combined use with an interrupt input)
 - Instructions : 63
 - Two interrupt sources (1 internal, 1 external)
 - Power down features
 - Minimum instruction execution time : 952 ns @ 4.2 MHz clock
 - Crystal and ceramic oscillation
 - Single 5 V power supply
 - Package options:
 - 24-pin plastic DIP (DIP24-P-600-2.54) : (Product name : MSM6422-××RS)
 - 24-pin plastic SOP (SOP24-P-430-1.27-K) : (Product name : MSM6422-××GS-K)
- ×× indicates a code number.

BLOCK DIAGRAM

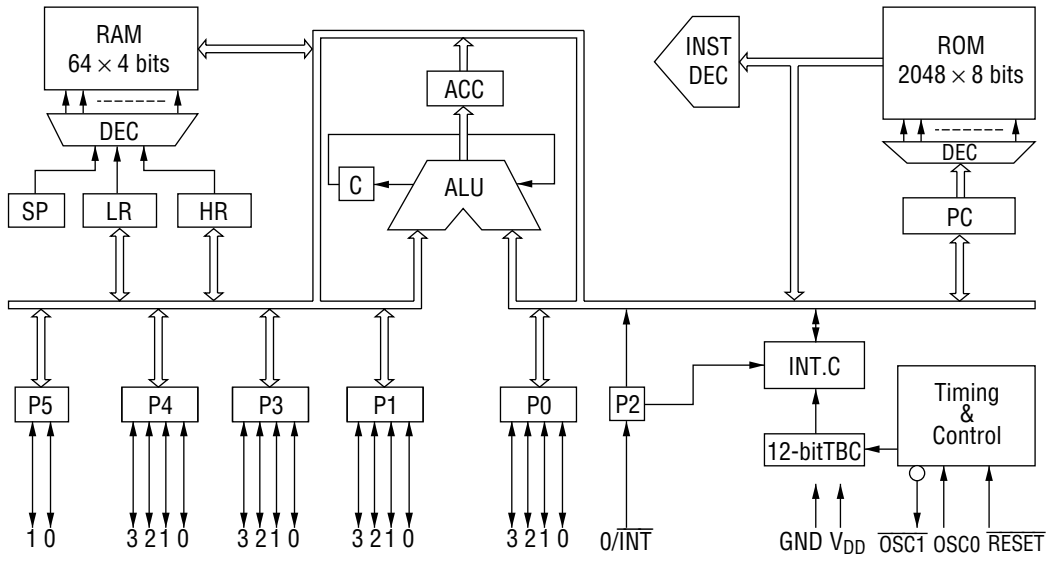

PIN CONFIGURATION (TOP VIEW)

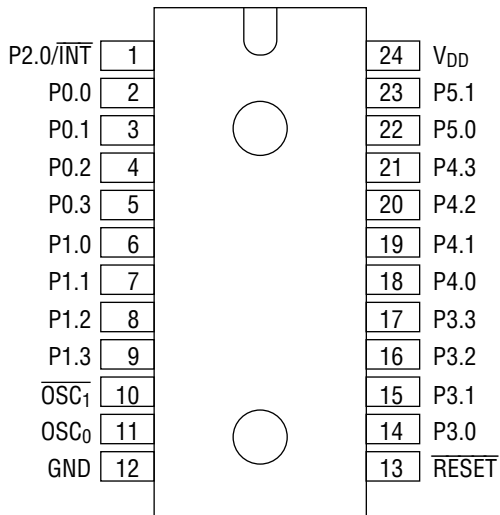

24-Pin Plastic DIP

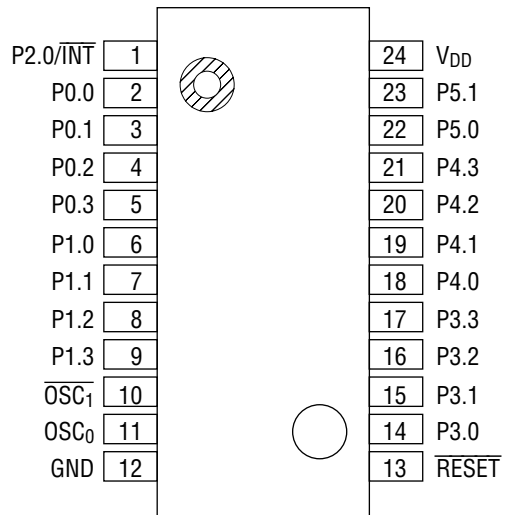

24-Pin Plastic SOP

PIN DESCRIPTIONS

Pin	Symbol	Type	Description	During reset
2	P0.0	I/O	4-bit input-output port (pseudo bidirectional configuration)	"1"
3	P0.1			
4	P0.2			
5	P0.3			
6	P1.0	I/O	4-bit input-output port (pseudo bidirectional configuration)	"1"
7	P1.1			
8	P1.2			
9	P1.3			
14	P3.0	I/O	4-bit input-output port (pseudo bidirectional configuration)	"1"
15	P3.1			
16	P3.2			
17	P3.3			
18	P4.0	I/O	4-bit input-output port (pseudo bidirectional configuration)	"0"
19	P4.1			
20	P4.2			
21	P4.3			
22	P5.0	I/O	2-bit input-output port (pseudo bidirectional configuration)	"0"
23	P5.1			
1	P2.0/ $\overline{\text{INT}}$	I	1-bit input port with a latch Combined use with an interrupt input (falling edge trigger input)	The latch is reset to "0".
11	OSC ₀	I	System clock (SYSCLK) input pin This provides an oscillation circuit with $\overline{\text{OSC}}_1$ pin.	—
10	$\overline{\text{OSC}}_1$	O	System clock output pin This provides an oscillation circuit with OSC ₀ pin.	—
13	$\overline{\text{RESET}}$	I	RESET input pin	—
24	V _{DD}	I	Power supply voltage pins	—
12	GND	I	Ground pin	—

ABSOLUTE MAXIMUM RATINGS

Parameter	Symbol	Condition	Rating	Unit
Power Supply Voltage	V_{DD}	$T_a = 25^\circ\text{C}$	-0.3 to +7	V
Input Voltage	V_I		-0.3 to V_{DD}	V
Output Voltage	V_O		-0.3 to V_{DD}	V
Power Dissipation	P_D	$T_a = 25^\circ\text{C}$ per package	200 max.	mW
		$T_a = 25^\circ\text{C}$ per output	50 max.	mW
Storage Temperature	T_{STG}	—	-55 to +150	$^\circ\text{C}$

RECOMMENDED OPERATING CONDITIONS

Parameter	Symbol	Condition	Range	Unit
Power Supply Voltage	V_{DD}	$f_{OSC} \leq 1 \text{ MHz}$	3 to 6	V
		$f_{OSC} \leq 4.2 \text{ MHz}$	4.5 to 5.5	V
Data-Hold Voltage	V_{DDH}	$f_{OSC} = 0 \text{ Hz}$	2 to 6	V
Operating Temperature	T_{op}	—	-40 to +85	$^\circ\text{C}$
Fan Out	N	MOS load	15	—
		TTL load	1	—

ELECTRICAL CHARACTERISTICS

DC Characteristics

($V_{DD} = 5\text{ V} \pm 10\%$, $T_a = -40$ to $+85^\circ\text{C}$)

Parameter	Symbol	Condition	Min.	Typ.	Max.	Unit
"H" Input Voltage*1, *2	V_{IH}	—	2.4	—	V_{DD}	V
"H" Input Voltage*3, *4	V_{IH}	—	4.2	—	V_{DD}	V
"L" Input Voltage	V_{IL}	—	-0.3	—	+0.8	V
"H" Output Voltage*1, *5	V_{OH}	$I_O = -15\ \mu\text{A}$	4.2	—	—	V
"L" Output Voltage*1	V_{OL}	$I_O = 1.6\ \text{mA}$	—	—	0.4	V
"L" Output Voltage*5	V_{OL}	$I_O = 15\ \mu\text{A}$	—	—	0.4	V
Input Current*3	I_{IH}/I_{IL}	$V_I = V_{DD}/0\ \text{V}$	—	—	15/-15	μA
Input Current*2, *4	I_{IH}/I_{IL}	$V_I = V_{DD}/0\ \text{V}$	—	—	1/-30	μA
"H" Output Current*1	I_{OH}	$V_O = 2.4\ \text{V}$	-0.1	—	—	mA
"H" Output Current*1	I_{OH}	$V_O = 0.4\ \text{V}$	—	—	-1.2	mA
Input Capacitance	C_I	$f = 1\ \text{MHz}$, $T_a = 25^\circ\text{C}$	—	5	—	μF
Output Capacitance	C_O		—	7	—	
Power Supply Current (In Stop Mode)	I_{DDs}	$V_{DD} = 2\ \text{V}$, no load, $T_a = 25^\circ\text{C}$	—	0.2	5	μA
		No load	—	1	100	μA
Power Supply Current	I_{DD}	Crystal oscillation, no load, 4.2 MHz	—	6	12	mA

*1 Applied to P0, P1, P3, P4, and P5

*2 Applied to P2

*3 Applied to $\overline{\text{OSC}}_0$

*4 Applied to $\overline{\text{RESET}}$

*5 Applied to $\overline{\text{OSC}}_1$

AC Characteristics

($V_{DD} = 5\text{ V} \pm 10\%$, $T_a = -40\text{ to }+85^\circ\text{C}$)

Parameter	Symbol	Condition	Min.	Typ.	Max.	Unit
Clock (OSC ₀) Pulse Width	$t_{\phi W}$	—	119	—	—	ns
Cycle Time	t_{CY}	—	952	—	—	ns
Input Data Setup Time	t_{DS}	—	120	—	—	ns
Input Data Hold Time	t_{DH}	—	120	—	—	ns
Input Data/Input Clock Pulse Width	t_{DW}	—	120	—	—	ns
Data Delay Time	t_{DR}	$C_L = 15\text{ pF}$	—	—	$t_{CY} + 300$	ns

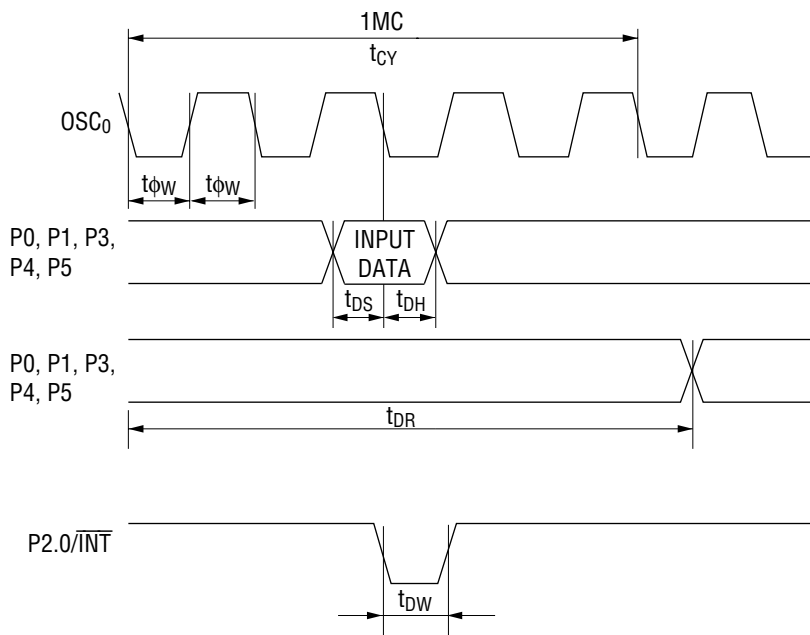

Operating Characteristics

Current (I_{OH}) vs Voltage (V_{OH}) for High Level Output

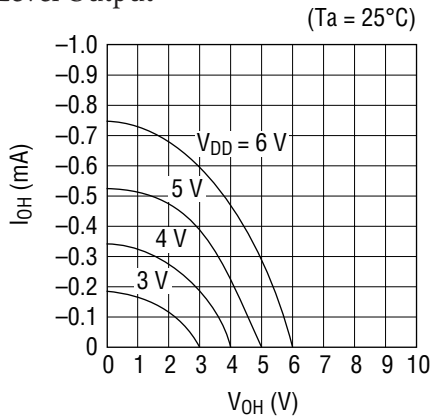

Current (I_{OL}) vs Voltage (V_{OL}) for Low Level Output

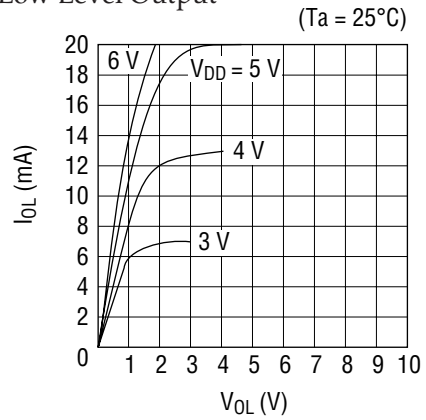

Maximum Clock Frequency (f_{OSC}) vs Supply Voltage (V_{DD})

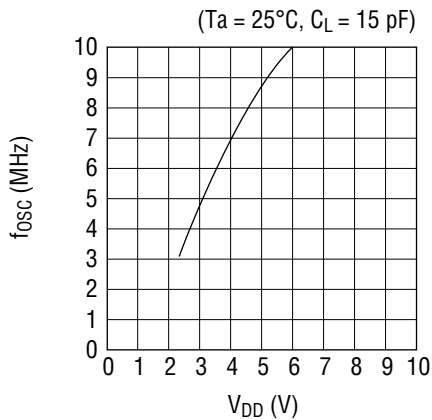

Supply Current (I_{DD}) vs Supply Voltage (V_{DD})

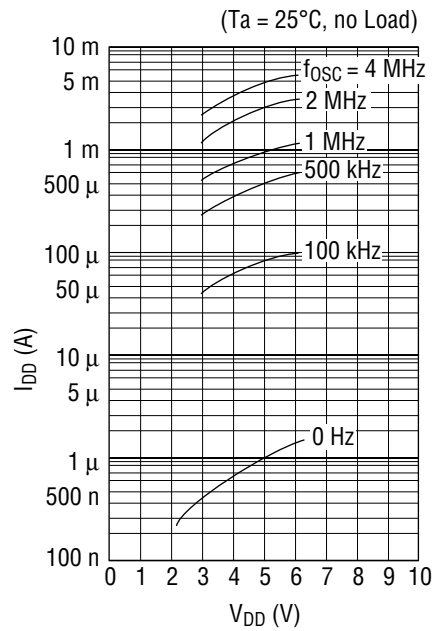

Maximum Clock Frequency (f_{OSC}) vs Ambient Temperature (T_a)

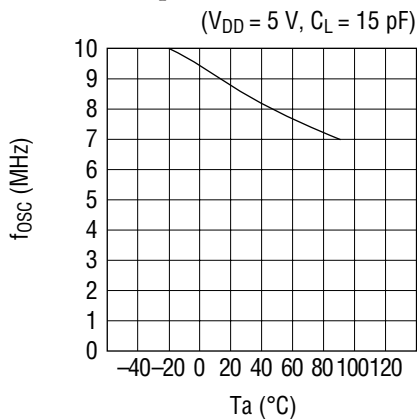

PACKAGE DIMENSIONS

(Unit : mm)

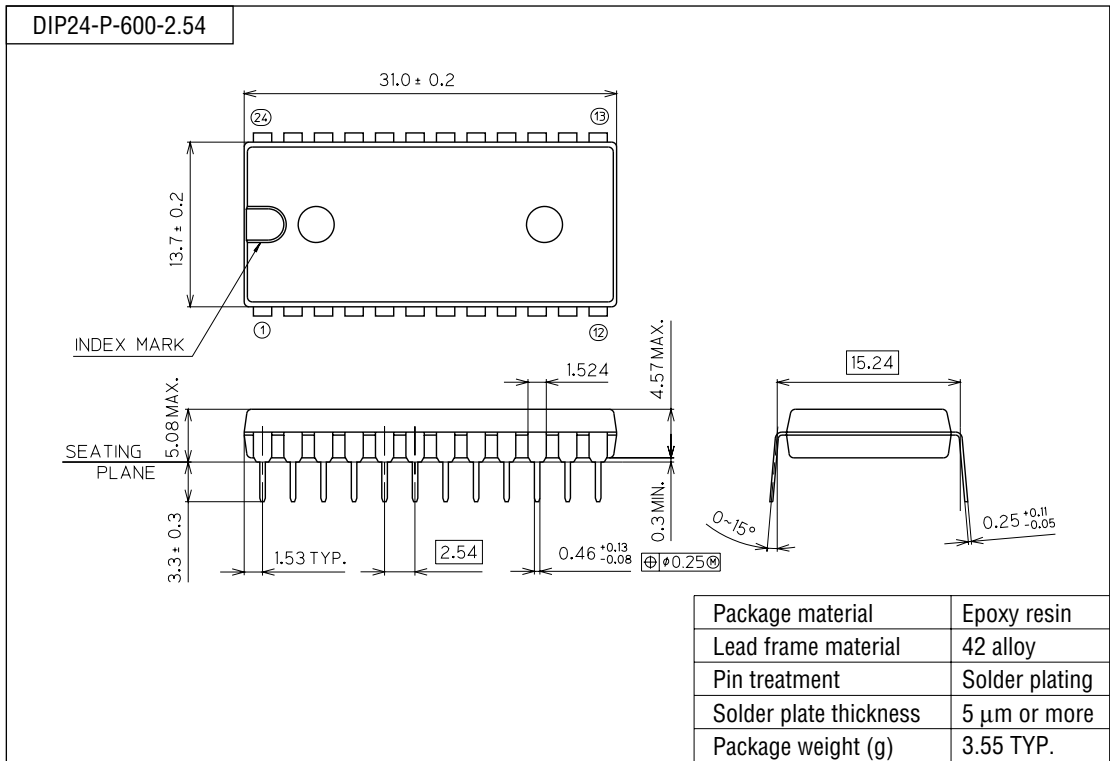

(Unit : mm)

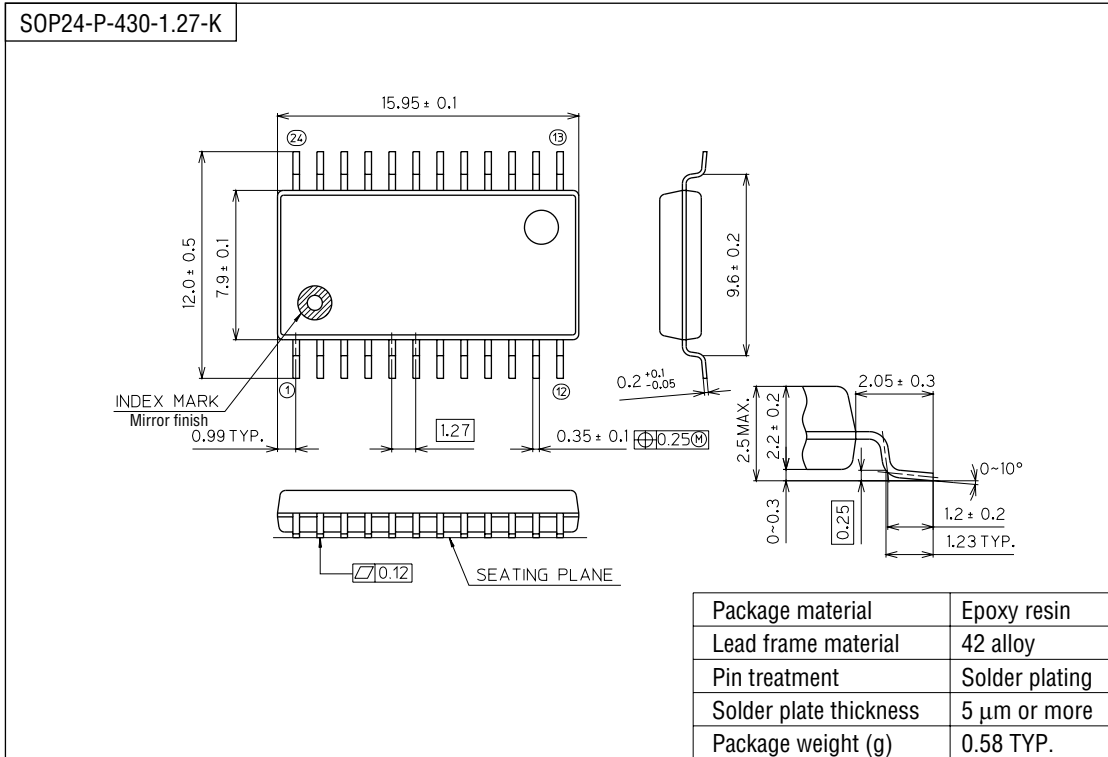

Notes for Mounting the Surface Mount Type Package

The SOP, QFP, TSOP, SOJ, QFJ (PLCC), SHP and BGA are surface mount type packages, which are very susceptible to heat in reflow mounting and humidity absorbed in storage. Therefore, before you perform reflow mounting, contact Oki's responsible sales person for the product name, package name, pin number, package code and desired mounting conditions (reflow method, temperature and times).