

OKI Semiconductor

FEDR27T12802L-02-01

Issue Date: August 7, 2006

MR27T12802L

8M-Word × 16-Bit or 16M-Word × 8-Bit **P2ROM**

FEATURES

- 8,388,608-word × 16-bit / 16,777,216-word × 8-bit electrically switchable configuration
- Access time
 - 2.7 V to 3.6 V power supply 100 ns MAX
 - 3.0 V to 3.6 V power supply 90 ns MAX
- Operating current 25 mA MAX(5MHz)
- Standby current 10 μA MAX
- Input/Output TTL compatible
- Three-state output

PACKAGES

- MR27T12802L-xxxTA
56-pin plastic TSOP (TSOP I 56-P-1420-0.50-K)

P2ROM ADVANCED TECHNOLOGY

P2ROM stands for Production Programmed ROM. This exclusive Oki technology utilizes factory test equipment for programming the customers code into the P2ROM prior to final production testing. Advancements in this technology allows production costs to be equivalent to MASKROM and has many advantages and added benefits over the other non-volatile technologies, which include the following;

- **Short lead time**, since the P2ROM is programmed at the final stage of the production process, a large P2ROM inventory "bank system" of un-programmed packaged products are maintained to provide an aggressive lead-time and minimize liability as a custom product.
- **No mask charge**, since P2ROMs do not utilize a custom mask for storing customer code, no mask charges apply.
- **No additional programming charge**, unlike Flash and OTP that require additional programming and handling costs, the P2ROM already has the code loaded at the factory with minimal effect on the production throughput. The cost is included in the unit price.
- **Custom Marking is** available at no additional charge.
- **Pin Compatible** with some FLASH products except for 29-pin.

PIN CONFIGURATION (TOP VIEW)

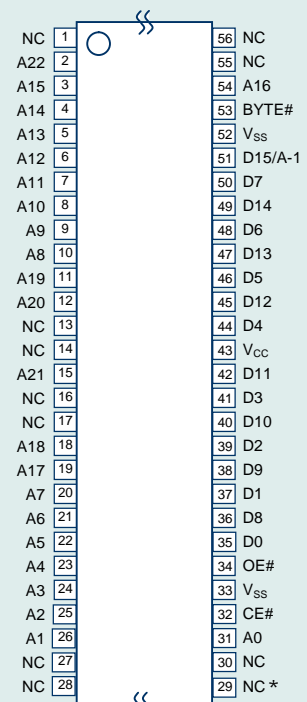

* : Different from FLASH products.

BLOCK DIAGRAM

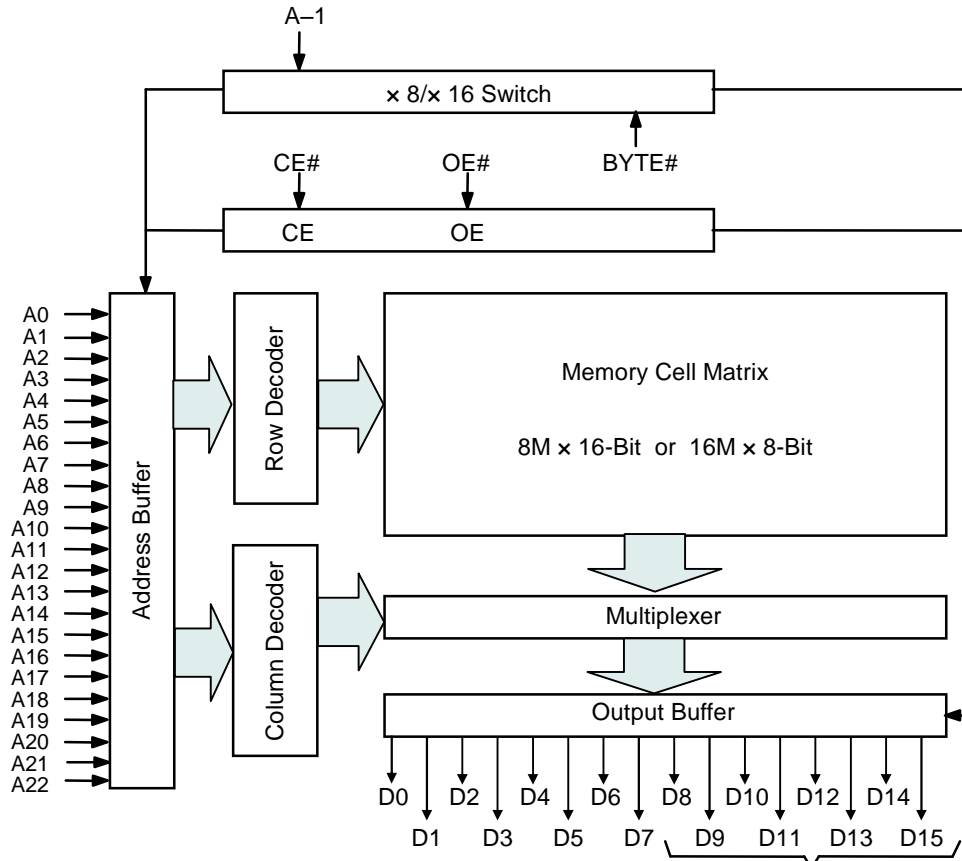

In 8-bit output mode, these pins are placed in a high-Z state and pin D15 functions as the A-1 address pin.

PIN DESCRIPTIONS

Pin name	Functions
D15 / A-1	Data output / Address input
A0 to A22	Address inputs
D0 to D14	Data outputs
CE#	Chip enable input
OE#	Output enable input
BYTE#	Word / Byte select input
V _{cc}	Power supply voltage
V _{ss}	Ground

FUNCTION TABLE

Mode	CE#	OE#	BYTE#	V _{CC}	D0 to D7	D8 to D14	D15/A-1
Read (16-Bit)	L	L	H	2.7 V to 3.6 V	D _{OUT}		
Read (8-Bit)	L	L	L		D _{OUT}	Hi-Z	L/H
Output disable	L	H	H		Hi-Z		
			L			*	
Standby	H	*	H		Hi-Z		
			L			*	

*: Don't Care (H or L)

ABSOLUTE MAXIMUM RATINGS

Parameter	Symbol	Condition	Value	Unit
Operating temperature under bias	T _a	—	0 to 70	°C
Storage temperature	T _{stg}		-55 to 125	°C
Input voltage	V _I	relative to V _{SS}	-0.5 to V _{CC} +0.5	V
Output voltage	V _O		-0.5 to V _{CC} +0.5	V
Power supply voltage	V _{CC}		-0.5 to 5	V
Power dissipation per package	P _D	T _a = 25°C	1.0	W
Output short circuit current	I _{OS}	—	10	mA

RECOMMENDED OPERATING CONDITIONS

(T_a = 0 to 70°C)

Parameter	Symbol	Condition	Min.	Typ.	Max.	Unit
V _{CC} power supply voltage	V _{CC}	V _{CC} = 2.7 to 3.6 V	2.7	—	3.6	V
Input "H" level	V _{IH}		2.2	—	V _{CC} +0.5*	V
Input "L" level	V _{IL}		-0.5**	—	0.6	V

Voltage is relative to V_{SS}.

* : V_{CC}+1.5V(Max.) when pulse width of overshoot is less than 10ns.

** : -1.5V(Min.) when pulse width of undershoot is less than 10ns.

PIN CAPACITANCE

(V_{CC} = 3.0 V, T_a = 25°C, f = 1 MHz)

Parameter	Symbol	Condition	Min.	Typ.	Max.	Unit
Input	C _{IN1}	V _I = 0 V	—	—	10	pF
BYTE#	C _{IN2}		—	—	200	
Output	C _{OUT}	V _O = 0 V	—	—	10	

ELECTRICAL CHARACTERISTICS

DC Characteristics

($V_{CC} = 2.7\text{ V to }3.6\text{ V}$, $T_a = 0\text{ to }70^\circ\text{C}$)

Parameter	Symbol	Condition	Min.	Typ.	Max.	Unit
Input leakage current	I_{LI}	$V_I = 0\text{ to }V_{CC}$	—	—	10	μA
Output leakage current	I_{LO}	$V_O = 0\text{ to }V_{CC}$	—	—	10	μA
V_{CC} power supply current (Standby)	I_{CCSC}	$CE\# = V_{CC}$	—	—	10	μA
	I_{CCST}	$CE\# = V_{IH}$	—	—	1	mA
V_{CC} power supply current (Read)	I_{CCA}	$CE\# = V_{IL}$, $OE\# = V_{IH}$ $f=5\text{MHz}$	—	—	25	mA
Input "H" level	V_{IH}	—	2.2	—	$V_{CC}+0.5^*$	V
Input "L" level	V_{IL}	—	-0.5**	—	0.6	V
Output "H" level	V_{OH}	$I_{OH} = -1\text{ mA}$	2.4	—	—	V
Output "L" level	V_{OL}	$I_{OL} = 2\text{ mA}$	—	—	0.4	V

Voltage is relative to V_{SS} .

* : $V_{CC}+1.5\text{V}$ (Max.) when pulse width of overshoot is less than 10ns.

** : -1.5V (Min.) when pulse width of undershoot is less than 10ns.

AC Characteristics

(V_{CC} = 2.7 V to 3.6 V, T_a = 0 to 70°C)

Parameter	Symbol	Condition	Min.	Max.	Unit
Address cycle time	t _C	—	100	—	ns
Address access time	t _{ACC}	CE# = OE# = V _{IL}	—	100	ns
CE# access time	t _{CE}	OE# = V _{IL}	—	100	ns
OE# access time	t _{OE}	CE# = V _{IL}	—	30	ns
Output disable time	t _{CHZ}	OE# = V _{IL}	0	20	ns
	t _{OHZ}	CE# = V _{IL}	0	20	ns
Output hold time	t _{OH}	CE# = OE# = V _{IL}	0	—	ns

(V_{CC} = 3.0 V to 3.6 V, T_a = 0 to 70°C)

Parameter	Symbol	Condition	Min.	Max.	Unit
Address cycle time	t _C	—	90	—	ns
Address access time	t _{ACC}	CE# = OE# = V _{IL}	—	90	ns
CE# access time	t _{CE}	OE# = V _{IL}	—	90	ns
OE# access time	t _{OE}	CE# = V _{IL}	—	30	ns
Output disable time	t _{CHZ}	OE# = V _{IL}	0	20	ns
	t _{OHZ}	CE# = V _{IL}	0	20	ns
Output hold time	t _{OH}	CE# = OE# = V _{IL}	0	—	ns

Measurement conditions

Input signal level ----- 0 V/3 V
 Input timing reference level ----- 1/2V_{CC}
 Output load ----- 50 pF
 Output timing reference level ----- 1/2V_{CC}

Output load

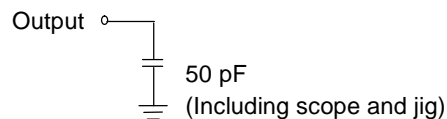

TIMING CHART (READ CYCLE)

16-BIT READ MODE (BYTE# = V_{IH})

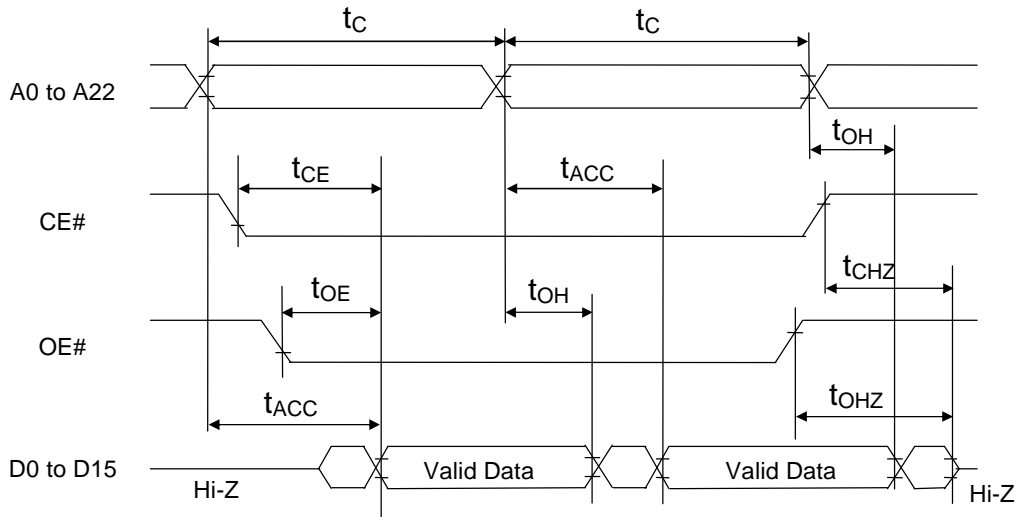

8-BIT READ MODE (BYTE# = V_{IL})

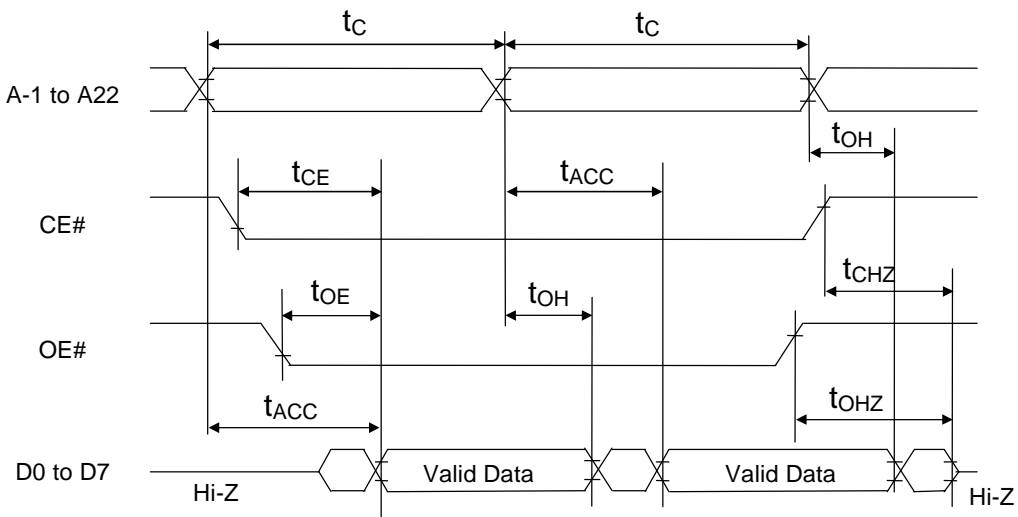

PACKAGE DIMENSIONS

(Unit: mm)

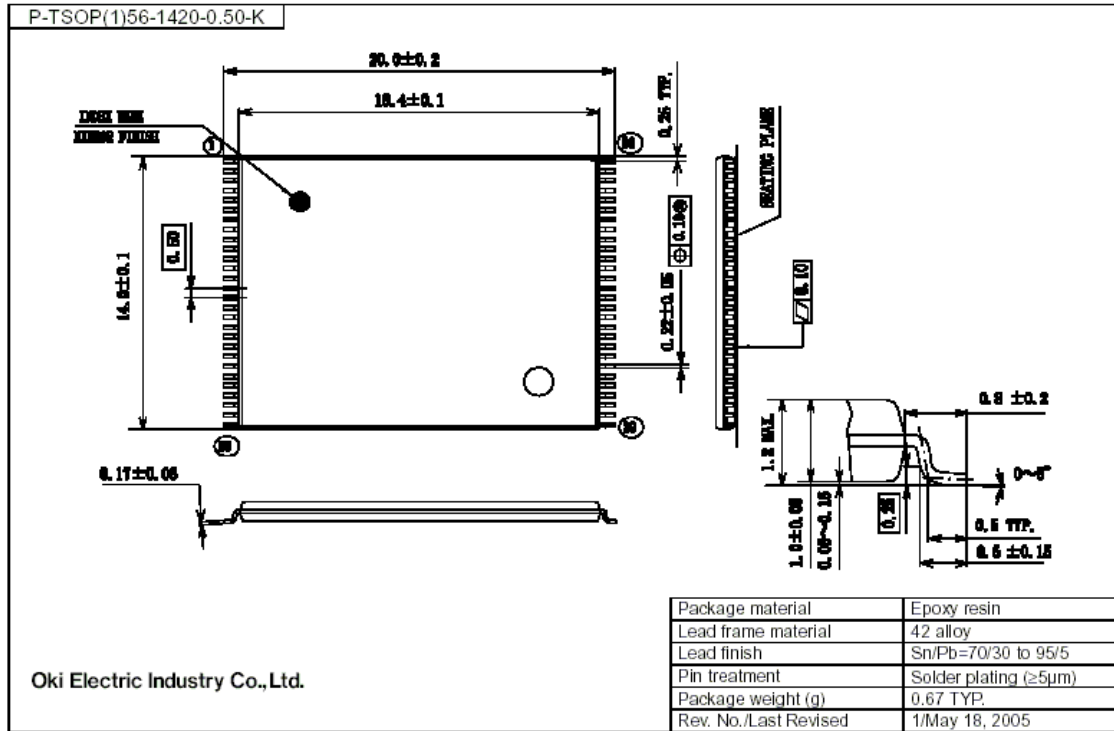

Notes for Mounting the Surface Mount Type Package

The surface mount type packages are very susceptible to heat in reflow mounting and humidity absorbed in storage.

Therefore, before you perform reflow mounting, contact Oki's responsible sales person for the product name, package name, pin number, package code and desired mounting conditions (reflow method, temperature and times).

REVISION HISTORY

Document No.	Date	Page		Description
		Previous Edition	Current Edition	
FEDR27T12802L-02-01	Aug. 7, 2006	–	–	Final edition 1

NOTICE

1. The information contained herein can change without notice owing to product and/or technical improvements. Before using the product, please make sure that the information being referred to is up-to-date.
2. The outline of action and examples for application circuits described herein have been chosen as an explanation for the standard action and performance of the product. When planning to use the product, please ensure that the external conditions are reflected in the actual circuit, assembly, and program designs.
3. When designing your product, please use our product below the specified maximum ratings and within the specified operating ranges including, but not limited to, operating voltage, power dissipation, and operating temperature.
4. Oki assumes no responsibility or liability whatsoever for any failure or unusual or unexpected operation resulting from misuse, neglect, improper installation, repair, alteration or accident, improper handling, or unusual physical or electrical stress including, but not limited to, exposure to parameters beyond the specified maximum ratings or operation outside the specified operating range.
5. Neither indemnity against nor license of a third party's industrial and intellectual property right, etc. is granted by us in connection with the use of the product and/or the information and drawings contained herein. No responsibility is assumed by us for any infringement of a third party's right which may result from the use thereof.
6. The products listed in this document are intended for use in general electronics equipment for commercial applications (e.g., office automation, communication equipment, measurement equipment, consumer electronics, etc.). These products are not, unless specifically authorized by Oki, authorized for use in any system or application that requires special or enhanced quality and reliability characteristics nor in any system or application where the failure of such system or application may result in the loss or damage of property, or death or injury to humans.
Such applications include, but are not limited to, traffic and automotive equipment, safety devices, aerospace equipment, nuclear power control, medical equipment, and life-support systems.
7. Certain products in this document may need government approval before they can be exported to particular countries. The purchaser assumes the responsibility of determining the legality of export of these products and will take appropriate and necessary steps at their own expense for these.
8. No part of the contents contained herein may be reprinted or reproduced without our prior permission.

Copyright 2006 Oki Electric Industry Co., Ltd.