

DIP20-P-300-2.54-W1

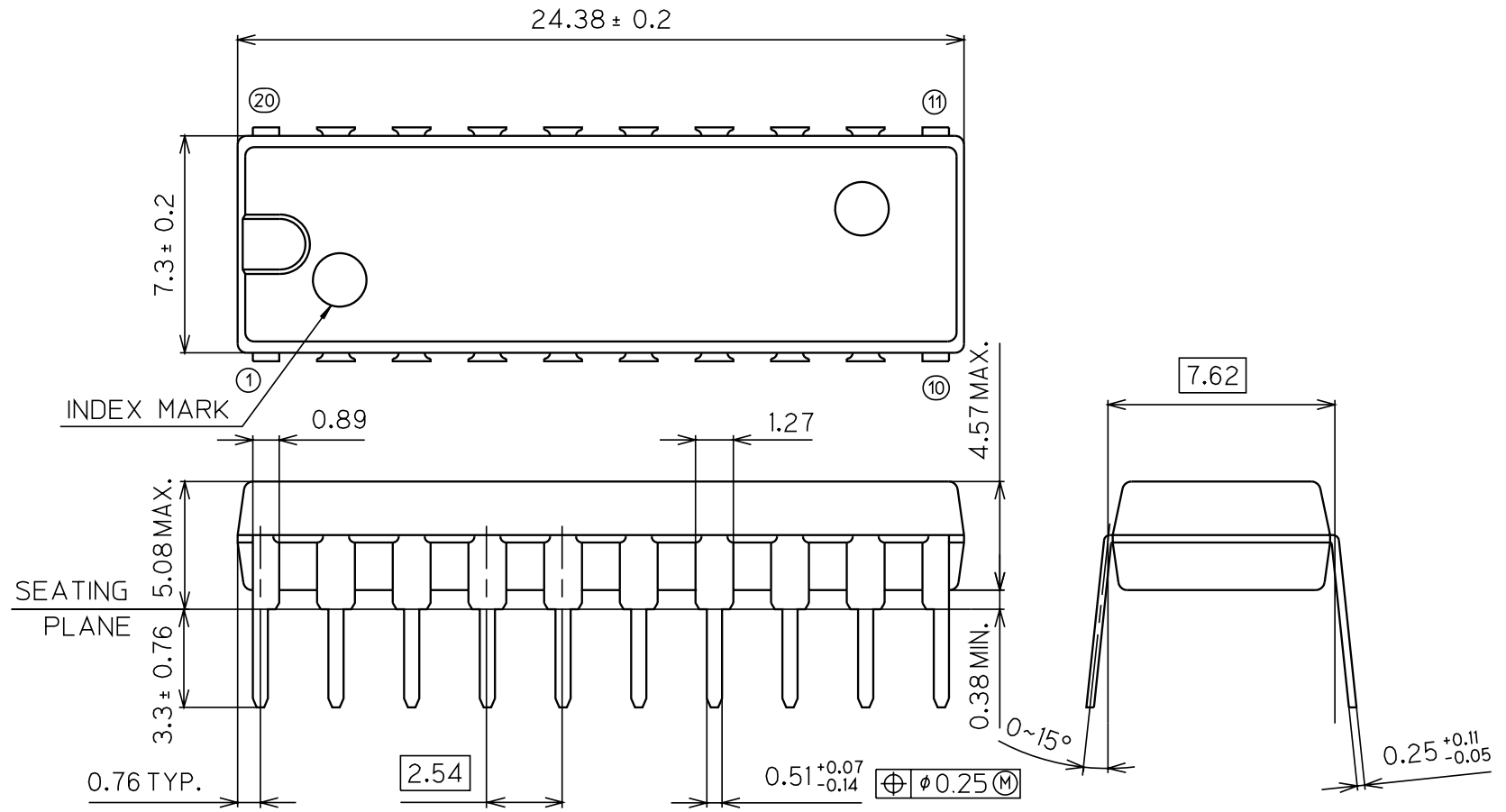

Package material	Epoxy resin
Lead frame material	42 alloy
Pin treatment	Solder plating ($\geq 5\mu\text{m}$)
Package weight (g)	1.50 TYP.
Rev. No./Last Revised	2/Dec. 11, 1996

Oki Electric Industry Co., Ltd.