

KGL4185KD Advanced Information

11.3 Gbps Direct Modulation Driver IC

FEATURES

- Maximum Input Data Rate : Up to 11.3Gbps
- Modulation Current Control : 20mApp - 80mApp at 25Ω Load
- Bias Current Control : 5mA - 60mA
- Crossing Point Controllability : 35% - 65%

FUNCTION DIAGRAM

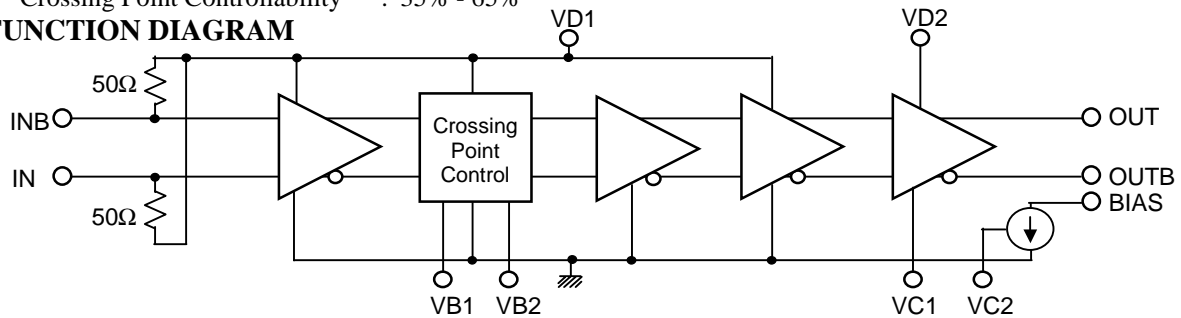

ABSOLUTE MAXIMUM RATINGS

Parameter	Symbol	Min	Max	Unit	Note
Supply Voltage	VD1	-0.3	4.0	V	
Supply Voltage of Output Stage	VD2	-0.3	6.0	V	
X-Point Control and Reference Voltage	VB1/VB2	-1.0	2.4	V	
Output Amplitude Control Voltage	VC1	-1.0	1.6	V	
Output Bias Control Voltage	VC2	-1.0	2.6	V	
Input Amplitude	Vin	-	1.5	Vpp	AC coupled
Operating Temperature at Package Base	Ts	-10	100	°C	
Storage Temperature	Tst	-40	125	°C	

RECOMMENDED OPERATING CONDITIONS

Parameter	Symbol	Min	Typ	Max	Unit	Note
Supply Voltage	VD1	3.13	3.3	3.47	V	
Supply Voltage of Output Stage	VD2	3.13	3.3	3.47	V	AC coupled using Bias-Tee
		4.75	5.0	5.25	V	DC coupled
X-Point Control Voltage	VB1	0.6	1.2	1.8	V	
X-Point Reference Voltage	VB2 ¹⁾	1.0	1.2	1.4	V	
Output Amplitude Control Voltage	VC1	0	-	1.2	V	
Output Bias Control Voltage	VC2	0	-	2.4	V	
Single-ended Input Amplitude	Vin	0.4	-	1.2	Vpp	AC coupled
Differential Input Amplitude		0.2	-	1.2	Vpp	AC coupled
Low Voltage of Modulation Current Output	VL(OUT)	1.5	-	-	V	
Low Voltage of Bias Current Output	VL(BIAS)	1.9	-	-	V	
Operating Temperature at Package Base	Ts	0	-	85	°C	
Input Interface	AC coupled (External blocking capacitor is required)					
Output Interface	DC coupled (Need 25Ω termination to VD2) or AC coupled (External Bias-Tee is required to supply output bias)					

1) VB2 can be opened or biased by the external circuit. For VB2 opened, VB2 is biased at about 1.2V (VD1=3.3V).

ELECTRICAL CHARACTERISTICS (TARGET SPECIFICATIONS)

This table is electrical characteristics at “OUT” port.
 “OUTB” port characteristics is TBD.

Parameter	Symbol	Condition	Min	Typ	Max	Unit
Maximum Input Data Rate		NRZ	11.3	-	-	Gbps
Supply Current	Id1	50 Ω load	-	120	-	mA
Supply Current	Id2	AC coupled using Bias-Tee, VD2=3.3V, 25Ω load, I _{mod} =80mApp, Excluding Bias Current	-	125	-	mA
		DC coupled, VD2=5.0V, 25Ω load, I _{mod} =80mApp, Excluding Bias Current	-	125	-	
Power Consumption	Pwr	AC coupled using Bias-Tee, VD2=3.3V, 25Ω load, I _{mod} =50mApp, Excluding Bias Current	-	0.65	-	W
		DC coupled, VD2=5.0V, 25Ω load, I _{mod} =50mApp, Excluding Bias Current	-	0.77	-	
Minimum Modulation Current	I _{mod} (min)	25 Ω load	-	20	30	mApp
Maximum Modulation Current	I _{mod} (max)	25 Ω load	70	80	-	mApp
Minimum Bias Current	I _B (min)		-	5	8	mA
Maximum Bias Current	I _B (max)		60	80	-	mA
X-Point Control Range	High	XPH	25 Ω load, NRZ	60	65	%
	Low	XPL		-	35	40
X-Point Stability	Del (Xp)	25 Ω load, 0–85°C	-10	-	10	%
Output Rise/Fall Time	Tr/Tf	25 Ω load, 20%/80%	-	27	-	ps
Input Return Loss	S11	100kHz–10GHz	-	12	-	dB

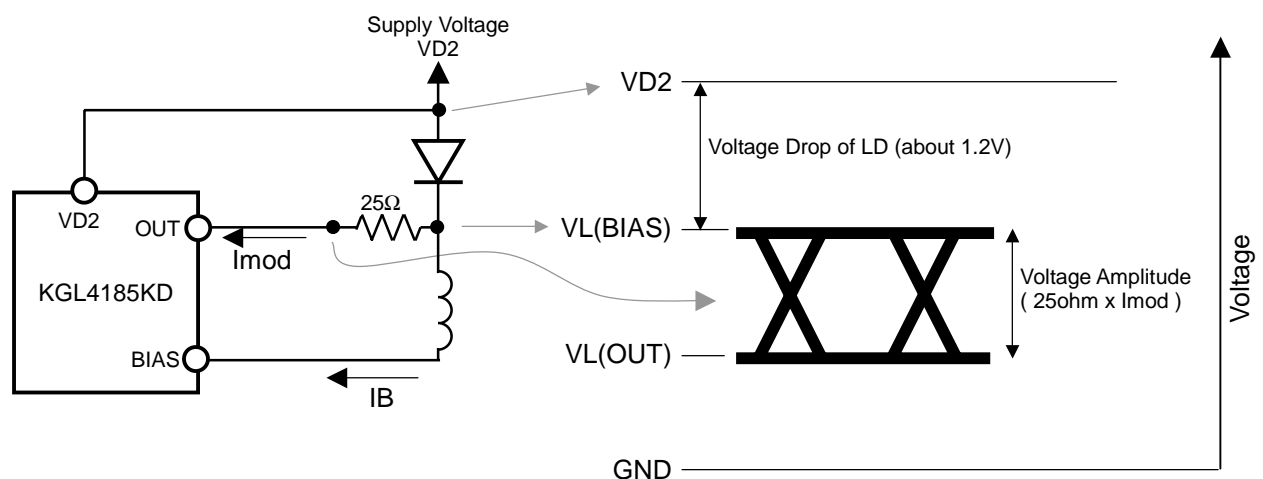

PACKAGE DIMENSIONS

(Top View)

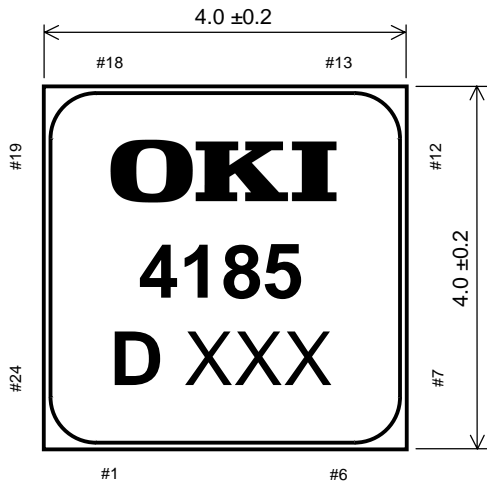

(Side View)

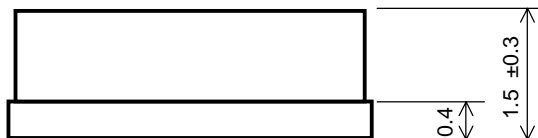

(Bottom View)

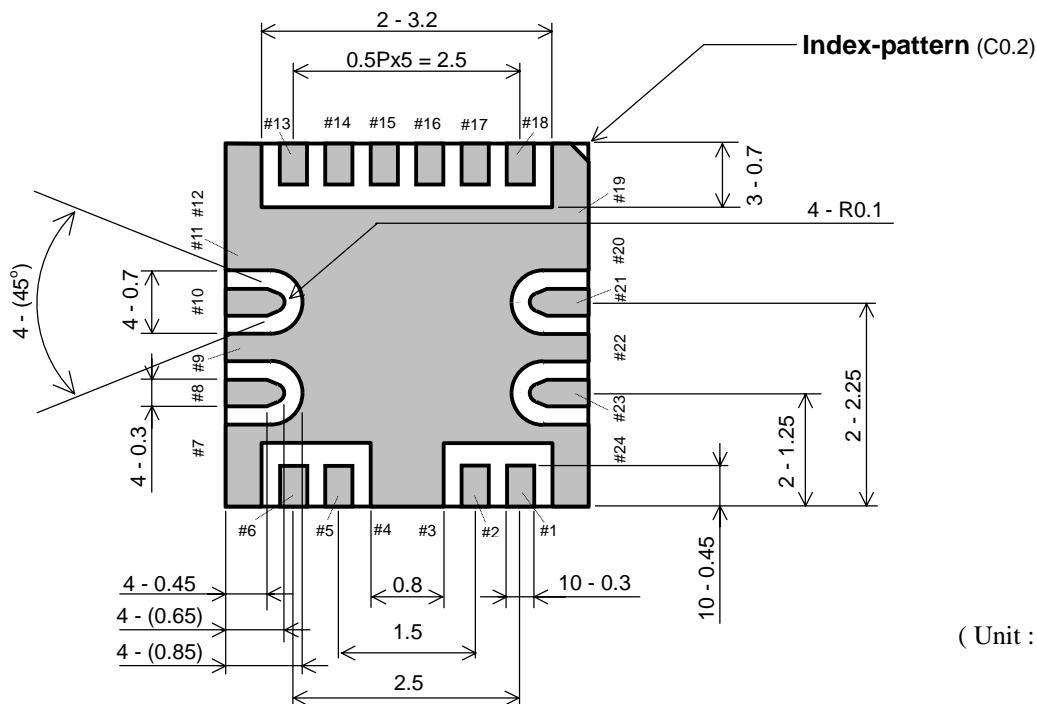

(Unit : mm)

PIN CONNECTION

No.	Symbol	Note
1	GND	Ground
2	Mon1	TBD
3	GND	Ground
4	GND	Ground
5	Mon2	TBD
6	BIAS	Bias Current Output Port
7	GND	Ground
8	OUT	Output Port
9	GND	Ground
10	OUTB	Inverted Output Port
11	GND	Ground
12	GND	Ground
13	VC2	Bias Control Port
14	VC1	Modulation Current Control Port
15	VD2	Supply Voltage Port
16	VD1	Supply Voltage Port
17	VB2	X-Point Reference Port
18	VB1	X-Point Control Port
19	GND	Ground
20	GND	Ground
21	INB	Inverted Input Port
22	GND	Ground
23	IN	Signal Input Port
24	GND	Ground

Note : This package is non-hermetic. This package specification is subject to change without notice.

TYPICAL APPLICATION (DC coupled)

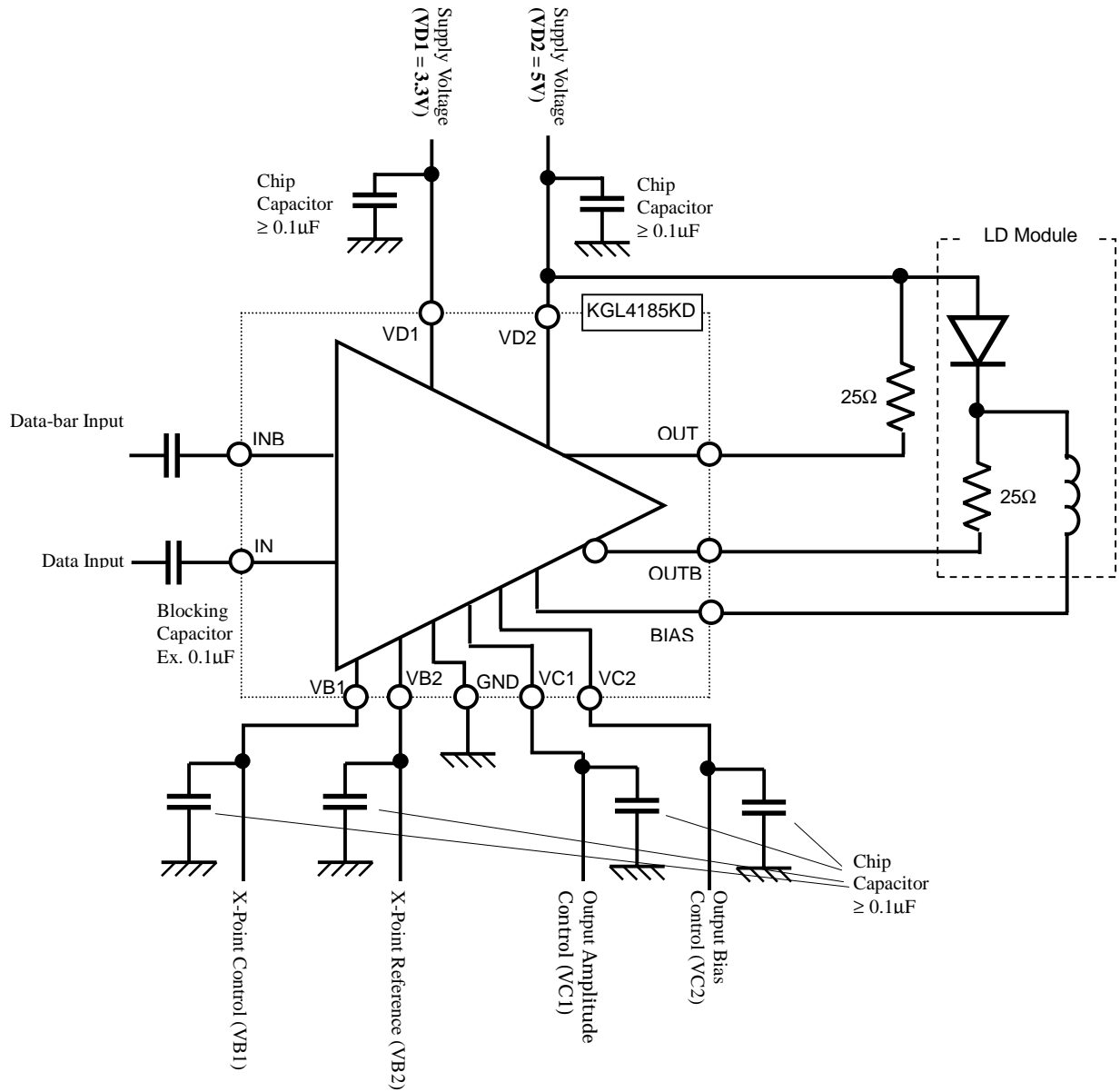

TYPICAL APPLICATION (AC coupled)

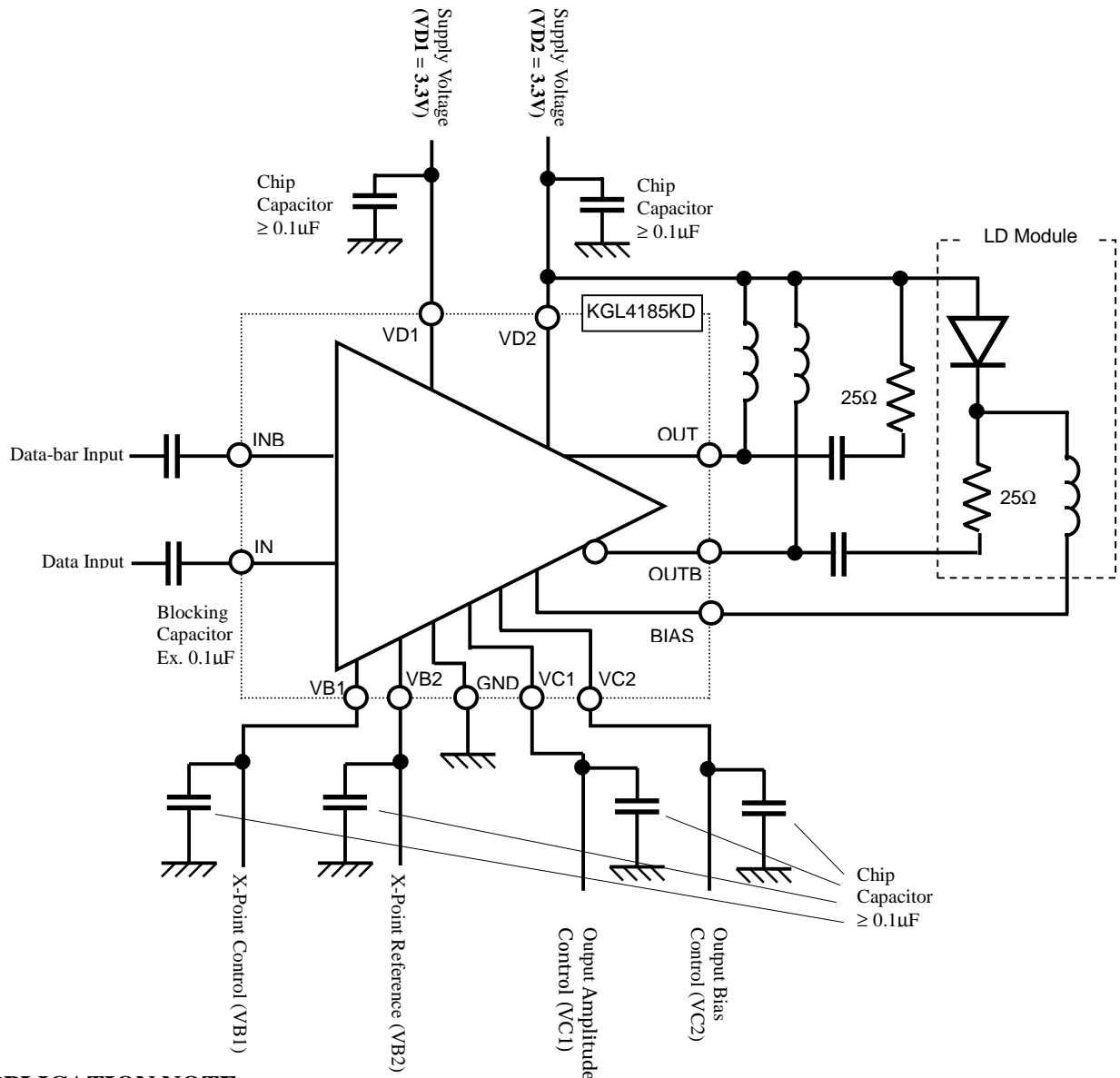

APPLICATION NOTE

1. For stable operation;

To prevent a dependence of "X-Point" on the supply voltage VD1,

Case 1 : VB2 is open

VB2 is biased at about $0.364 \times VD1$ (1.2V@VD1=3.3V) by the internal circuit.

Control VB1, so that the voltage difference "VB1-VB2" is constant.

Case 2 : VB2 is biased

Bias VB2 at about 1.2V by using the external voltage source independent of VD1.

Control VB1 by using the external voltage source independent of VD1.

2. Power-up/shut-down sequence;

For power-up, supply voltage (VD2) at first, next supply voltage (VD1), then control voltages (VB1, (VB2), VC1, VC2).

For shut-down, control voltages(VB1, (VB2), VC1, VC2). at first, next VD1, then VD2.

Customer does not need to care about the sequence for the control voltages (VB1,(VB2),VC1,VC2).

SAFETY AND HANDLING INFORMATION ON GaAs DEVICES

Arsenic Compound (GaAs Devices)

The product contains arsenic (As) as a compound.

This material is stable for normal use, however, its dust or vapor may be potentially hazardous to the human body.

Avoid ingestion, fracture, burning or chemical treatment to the product.

- Do not put the product in your mouth.
- Do not burn or destroy the product.
- Do not perform chemical treatment for the product.

Keep laws and ordinances related to the disposal of the products.

NOTICE

1. The information contained herein can change without notice owing to product and/or technical improvements. Before using the product, please make sure that the information being referred to is up-to-date.
2. The outline of action and examples for application circuits described herein have been chosen as an explanation for the standard action and performance of the product. When planning to use the product, please ensure that the external conditions are reflected in the actual circuit, assembly, and program designs.
3. When designing your product, please use our product below the specified maximum ratings and within the specified operating ranges including, but not limited to, operating voltage, power dissipation, and operating temperature.
4. Oki assumes no responsibility or liability whatsoever for any failure or unusual or unexpected operation resulting from misuse, neglect, improper installation, repair, alteration or accident, improper handling, or unusual physical or electrical stress including, but not limited to, exposure to parameters beyond the specified maximum ratings or operation outside the specified operating range.
5. Neither indemnity against nor license of a third party's industrial and intellectual property right, etc. is granted by us in connection with the use of the product and/or the information and drawings contained herein. No responsibility is assumed by us for any infringement of a third party's right which may result from the use thereof.
6. The products listed in this document are intended for use in general electronics equipment for commercial applications (e.g., office automation, communication equipment, measurement equipment, consumer electronics, etc.). These products are not authorized for use in any system or application that requires special or enhanced quality and reliability characteristics nor in any system or application where the failure of such system or application may result in the loss or damage of property, or death or injury to humans. Such applications include, but are not limited to, traffic and automotive equipment, safety devices, aerospace equipment, nuclear power control, medical equipment, and life-support systems.
7. Certain products in this document may need government approval before they can be exported to particular countries. The purchaser assumes the responsibility of determining the legality of export of these products and will take appropriate and necessary steps at their own expense for these.
8. No part of the contents contained herein may be reprinted or reproduced without our prior permission.

Copyright 2004 Oki Electric Industry Co., Ltd.